

Spiral Lamp Shade

Assembly notes

A pair of alignment holes that use short pieces of filament as alignment pins are included with each component.

They are for joining the Base or the Fitter End to the Shade

The holes are blind.. They are small and start printing only after the first layer.

Clear the holes by poking the single layer "blind" with a small drill bit or sharp tool.

In the illustration below, arrows show the location of the alignment holes on the components

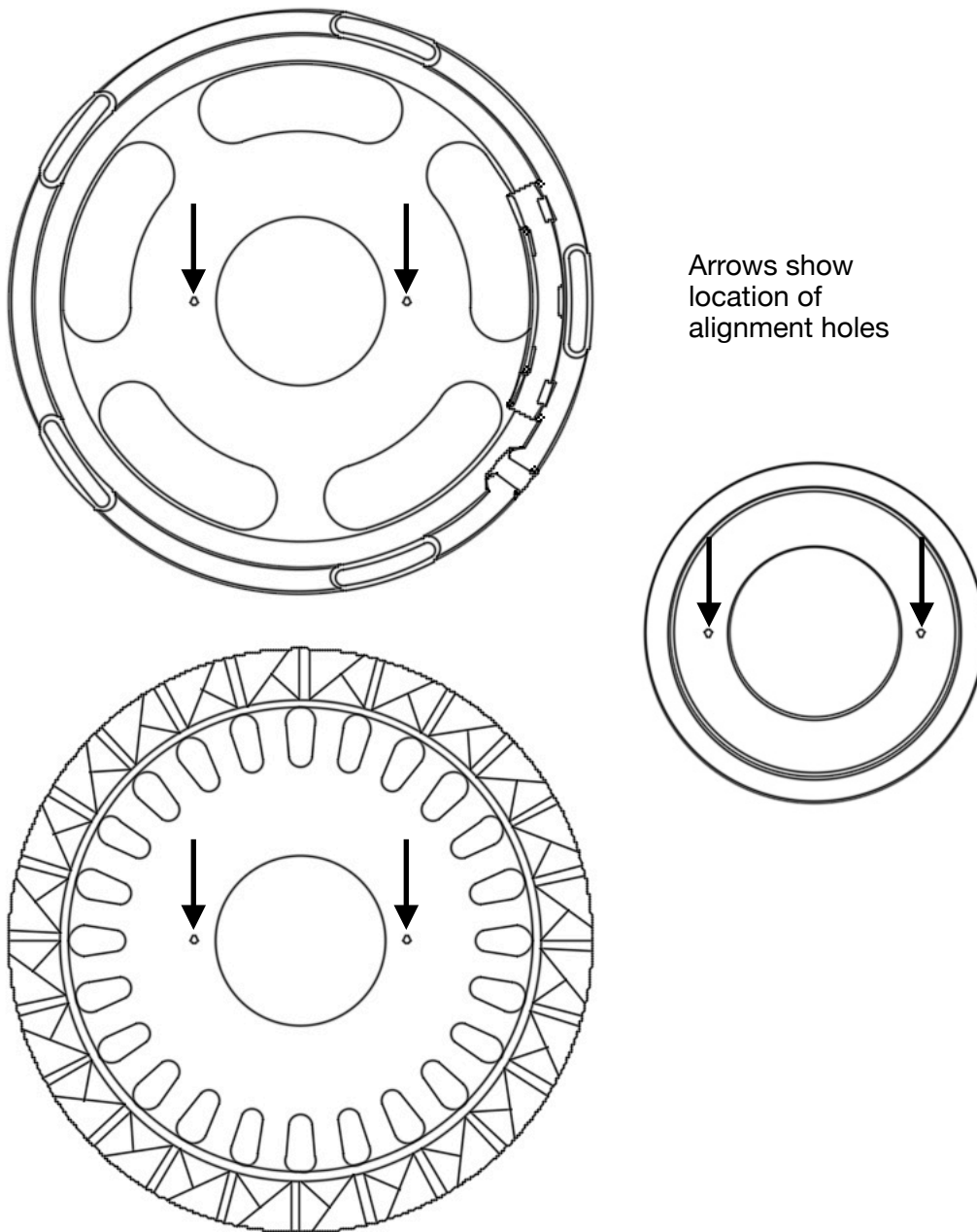

Use two short (~8mm) pieces of filament as **alignment pins** and glue the desired base to the Shade

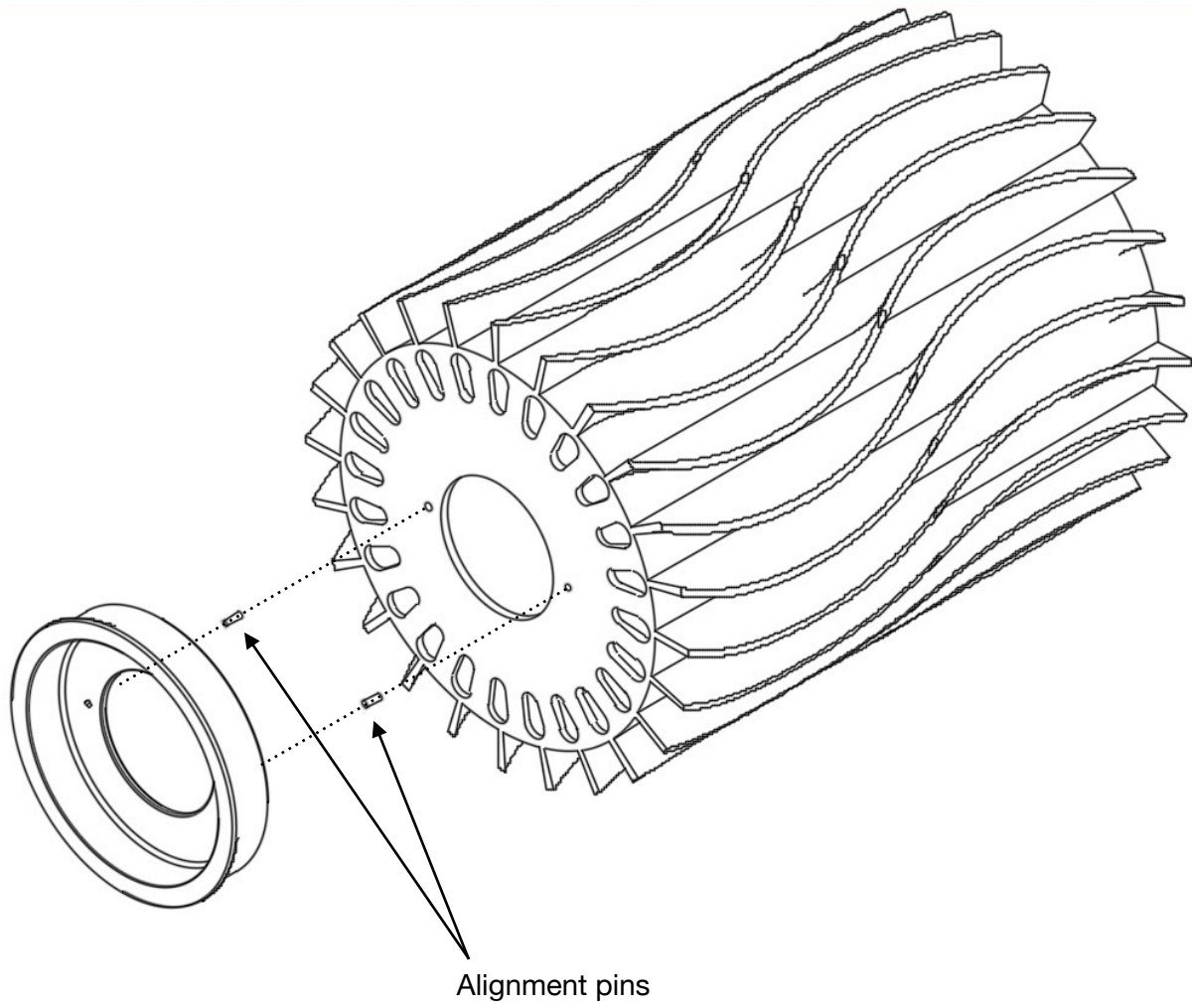

Base cord retainer path.
Route the electrical cord on the channel and secure with zip ties.

