

Dec. 13, 1938.

J. E. WILSON

2,140,275

WALKING TOY

Filed Oct. 15, 1936

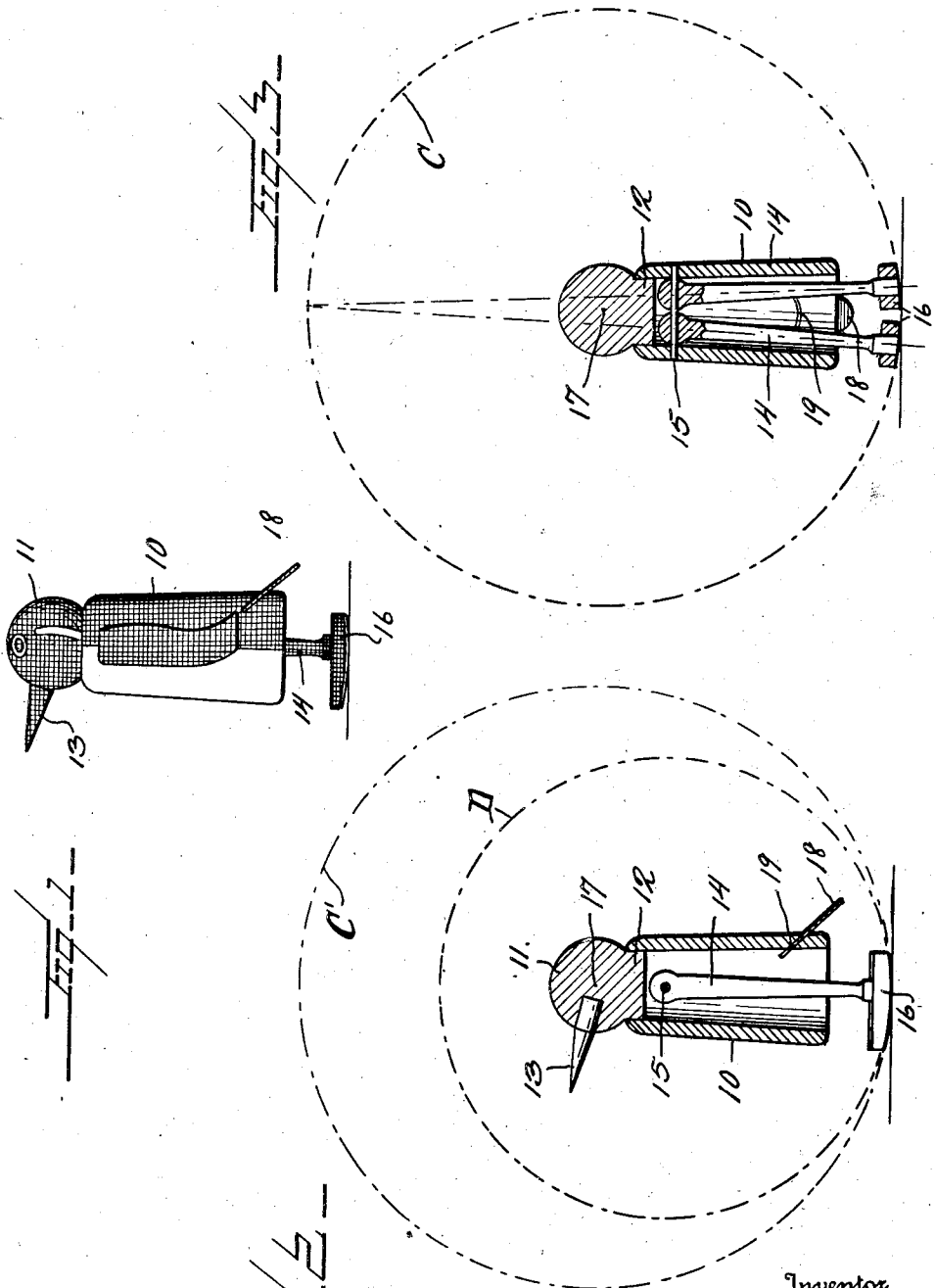

Inventor

J. E. Wilson

By *Watson E. Coleman*
Attorney

UNITED STATES PATENT OFFICE

2,140,275

WALKING TOY

John E. Wilson, Watsonstown, Pa., assignor of
one-half to Ned F. Wagner, Watsonstown, Pa.

Application October 15, 1936, Serial No. 105,768

1 Claim. (Cl. 46-149)

This invention relates to toys and particularly to walking toys, that is, toys having legs, the toy being so constructed that when impelled in one direction, the legs will alternately swing forward causing the toy to "walk".

The general object of this invention is to provide a toy of this character so constructed that when placed upon a surface having a very slight or gentle inclination, the legs of the toy will automatically alternately swing forward and the body of the toy will slightly swing from side to side, thus giving to the toy a very comical waddling motion.

Another object is to provide a toy of this character which is extremely simple and which is made of very few parts.

Other objects will appear in the course of the following description.

My invention is illustrated in the accompanying drawing wherein:

Figure 1 is a side elevation of a toy constructed in accordance with my invention.

Figure 2 is a vertical sectional view through the toy from front to rear.

Figure 3 is a vertical sectional view taken laterally through the toy.

Referring to these figures, 10 designates the body of the toy which, in the particular embodiment illustrated, is cylindrical or tubular. Disposed upon the body is a head 11 which is globular and which at its lower end is provided with a reduced portion 12 of such diameter that it may be forced into the upper end of the body 10 and glued therein or otherwise attached. The head 11 is shown as being formed with a beak 13 formed of a peg-like piece of wood or other material forced into the head 11.

Disposed within the body 10 are two legs 14, these legs being alike, and these legs at their upper ends are somewhat rounded on all sides and the legs are pivoted to the body 10 by means of a transverse pivot pin 15 which is driven through the body and which passes loosely through the legs, so that the legs can swing freely upon this pivot pin.

The lower ends of the legs are formed with feet 16. As illustrated, the feet are of a separate piece from the legs and the lower extremity of the legs are forced into the openings made in the feet and the feet glued onto the legs or otherwise rigidly attached thereto. The feet, as illustrated, are longer forward than they are rearward.

The underfaces of both feet, as shown most clearly in Figure 3 are transversely curved ac-

curately on a circle C, whose center is an imaginary point 17 in the center of the head. The feet also have a curvature from front to rear which is accurately the curvature of a circle C', whose center is the imaginary point 17. In other words, the two feet have the exact curvature of a sphere, whose exact center is the imaginary point 17, as clearly illustrated in Figures 2 and 3. The pivot point 15 of the legs 14 is disposed at the exact center of a circle D of considerably shorter radius than the circle C'. Thus the pivot point 15 is located a distance below the imaginary point 17 upon which the underfaces of the feet are struck.

I have illustrated my toy as having the form of a penguin, this form being particularly chosen because of the very comical, awkward, waddling gait of the penguin which my toy very closely simulates and hence I have provided the body 10 at its lower end with a tail 18, which is made of thin metal, cardboard or any other suitable material inserted in a kerf 19 formed in the body, this kerf extending upward and opening through the body. Wings 19' are also provided, these wings being formed of cardboard, metal or other suitable material and being attached to the body by glue or otherwise.

With the construction as described, it is merely necessary to set the toy upon a slightly inclined surface, preferably a surface inclined at an angle not greater than 1° and give a slight sidewise impulse to the body, whereupon the body will waddle down the incline, the legs being alternately swung forward and the toy having all the action of a penguin in walking.

Stress is laid upon the fact that the underfaces of the feet are formed as the exact surface of a sphere, the center of which is the imaginary center 17. This is absolutely essential to the proper operation of the toy. This permits the toy to, as it were, roll forward upon the feet and roll laterally upon the feet. The feet are spaced from each other a distance of approximately $\frac{1}{8}$ " at the nearest point and this spacing of the feet is also a very important factor in the operation of the toy.

In the operation of the toy, when the toy is placed upon a slightly inclined surface, the body rocks forward slightly and this carries the upper portion of the body, which in the case illustrated is the head 11, forward so that the point 17 moves forward of the pivot 15. If now the upper portion of the body be given a slight touch laterally or be even blown upon, one foot will be lifted from the surface and because of the ra-

dius of the legs being shorter than the radius of the curvature of the feet, the foot which has been carried out of touch with the surface by a slight lateral impulse will swing forward. Inasmuch as this foot has left the surface, the body will then tend to swing laterally, thus raising the other foot off the surface, and that too will swing forward, and thus the legs and feet will alternately swing forward, giving a waddling and walking motion to the body. If the surface is inclined but slightly uneven, the toy will follow the various inclinations of the surface so that it meanders in a very life-like manner, and so long as the surface is not too greatly inclined, the toy will maintain its equilibrium.

The space between the feet is of importance as, if there were no space between the feet, the toy would be only balanced as a ball is balanced and would be liable to tip over laterally. By reason of the spacing between the feet, however, the legs which extend downward and outward and the feet which are spaced from each other, act as two lateral braces bearing at their inner edges against the surface upon which the toy is supported and thereby preventing any lateral tipping movement of the toy until it is deliberately given a lateral impulse. When the toy swings from side to side so as to alternately lift the feet, the distance between the underface of the lifted foot is very slight, only just sufficient to permit the forward swing of the foot.

It is to be noted that the center upon which the curvature of the feet is struck is not only located above the pivotal axis of the legs but in a median plane of the body. It is also pointed out that the tail extending downward and rearward at the rear of the body tends to balance the bill and keep the center of gravity within the body.

It will be seen that in my toy no weights are necessary to throw the legs forward but the legs swing forward due to the fact that the center of motion of the legs is below the center upon which the under or tread faces of the feet are described. The lateral curvature given to the feet causes a smooth and easy lateral rocking motion of the body and only a very slight lateral impulse need be given to the body in order to start the figure walking.

It is an important point to be constantly borne in mind that the medial axes of the legs and feet are upwardly convergent and that these axes, extending from the bottom of the feet, if extended upward will intersect or meet at a point on the imaginary sphere C, which point is coaxial with the vertical axis of the body. With this construc-

tion, the body, after an initial impulse, will tilt laterally until the leg which is in contact with the supporting surface becomes vertical, then the body will swing laterally in the opposite direction until the other leg is vertical, and so on. The body thus has a swing in opposite directions of approximately 1° and will not become over-balanced if left alone and if it is travelling upon a surface inclined at 1° .

Attention is also called to the fact that the head does not project beyond the surfaces of the body but is entirely within the lines of the body so that there is no over-balancing action on the part of the head. It is also to be understood that the same principle may be applied to toys having different dimensions from those shown. In actual practice, I have made toys of this character which are considerably taller than the toy shown and which act precisely in the same manner. Because the legs extend upward into the body and are pivoted to the upper end thereof and the body extends downward around the legs a relatively considerable distance, the center of gravity is relatively low and hence the toy will not be top heavy.

While I have illustrated this toy as in the form of a penguin and believe this to be a particularly novel and attractive form of toy, I do not wish to be limited to a toy having these distinctive characteristics as obviously the principle of this toy might be applied in many different forms. It is sufficient if the toy has a body, legs and feet, the feet having their undersurfaces formed as portions of a true sphere, the center of which is disposed above the pivotal point of the legs and if the toy otherwise embodies the principles stated above.

What is claimed is:—

A walking toy, including a hollow body, a pair of legs extending up into the body and pivoted within the body for free forward and rear swinging movement, the pivot being adjacent the upper end of the body and feet on the legs, the tread surface of each foot being convex and curving in all directions, the curvature being that of the surface of an imaginary sphere whose center is located within the upper end portion of the body and in the central vertical axis of the body, the legs being upwardly convergent at such an angle that the longitudinal axes of the legs if extended will intersect each other and the surface of said imaginary sphere at the intersection of said vertical central axis of the body.

JOHN E. WILSON.