

# RIGID3D ANKA

## 1/10 RC SHORT COURSE TRUCK

English

Version 1.0

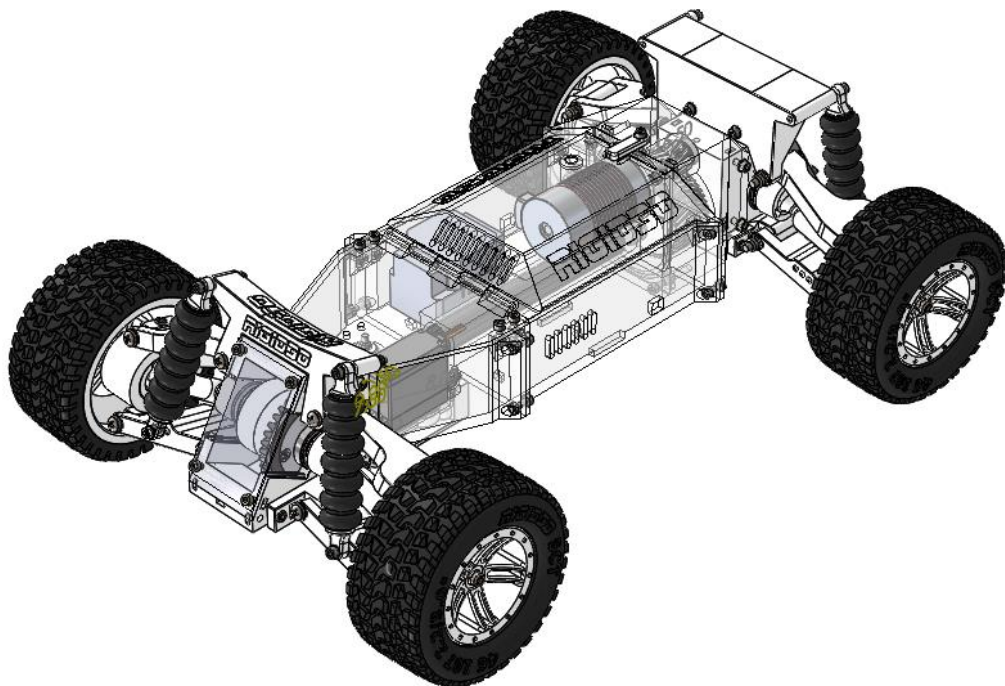

[Rigid3D Anka RC Truck](#) © 2022 by [Rigid3D](#) is licensed under [CC BY-SA 4.0](#)

## CONTENTS

CONTENTS .....	2
INTRODUCTION .....	3
LICENSE .....	3
LINKS .....	3
SPECIFICATIONS.....	4
NEEDED TOOLS .....	5
CONSUMABLES.....	5
NON-PRINTED PARTS BOM .....	6
PRINTED PARTS BOM & PRINT SETTINGS.....	7
EXPLODED DRAWINGS.....	14
DIFFERENTIAL INNER ASSY.....	14
DIFFERENTIAL ASSY.....	15
SHOCK ASSY .....	16
WHEEL ASSY.....	17
WHEEL SHAFT ASSY.....	18
FRONT ASSY .....	19
BACK ASSY.....	21
GEAR BOX ASSY .....	23
DRIVE SHAFT ASSY.....	24
RIGID3D SCT BACK ASSY .....	25
RIGID3D SCT Front ASSY.....	26
RIGID3D SCT V2 .....	28
BUMPER FRONT.....	29
BUMPER BACK.....	30

## INTRODUCTION

Anka is a mostly 3d printed 1/10 RC Short Course Truck which is inspired and remixed from the excellent Tarmo4 project. (You may reach the Tarmo4 project's details from [here](#).)

If you are a terrible driver like me, this hobby might become a bit expensive. Especially bashers may encounter lots of crashes and breakage which discourages the hobbyist. I wanted to design a basher which is mostly 3d printed so that I can drive it without worrying about crashes and breaks. I enjoy bashing more since I don't have to pay for the spares and wait for them to arrive.

The project is named Anka which is the Turkish equivalent of Phoenix from Greek or Simurgh from Persian mythology. After each crash broken parts are reprinted and the truck is reborn as does the immortal Anka which is reborn from its ashes.

In this model you can even print the shock absorbers and tires with TPU filament. But do not expect the performance of oil filled shocks or rubber tires from them.

Most of the parts may be printed with PLA and should work well with 2600KV motor and 2S LIPO battery. The material tested and recommended are shown in the file notes.

It can be printed on small printers. Most of the parts can be fit in a 15x15x15cm (6"x6"x6") build volume. Only the bumpers require at least 20x20cm (8"x8") print bed.

The truck is designed in the Short Course Truck (SCT) class. It meets the width and wheelbase dimension specifications of ROAR 1/10 Short Course Truck class.

The steering system is designed according to Ackermann geometry.

3d printed open differentials are used on both front and rear differentials.

Traxxas Slash or Remo Hobby short course truck body would fit on it perfectly. Body can be fixed to the chassis by glueing strong magnets.

You may reach the parametric design files from [github repository](#).

## LICENSE

Rigid3D Anka RC Truck © 2022 by Rigid3D is licensed under Attribution-ShareAlike 4.0 International. To view a copy of this license, visit <http://creativecommons.org/licenses/by-sa/4.0/>

## LINKS

TARMO4 Project	<a href="https://www.reddit.com/r/EngineeringNS/">https://www.reddit.com/r/EngineeringNS/</a>
STL Files	<a href="https://www.printables.com/model/214280">https://www.printables.com/model/214280</a>
GITHUB Repository (STL + Parametric Files)	<a href="https://github.com/mehmetutas/Rigid3D-Anka-RC-Short-Course-Truck">https://github.com/mehmetutas/Rigid3D-Anka-RC-Short-Course-Truck</a>
Rigid3D Website (Turkish)	<a href="https://www.rigid3d.com">https://www.rigid3d.com</a>
Anka Webpage (under development)	<a href="https://www.rigid3d.com/rigid3d-anka-rc-truck/">https://www.rigid3d.com/rigid3d-anka-rc-truck/</a>

You may use EngineeringNS subreddit to discuss issues about ANKA along with TARMO4.

## SPECIFICATIONS

Class	1/10 Expert Short Course Truck 4x4
Length	NA (will be available after bumper designs)
Front Track	296mm (with 3d printed tires)
Rear Track	296mm (with 3d printed tires)
Center Ground Clearance	67mm (with 3d printed tires and shocks)
Weight	2.3kgs (without battery / with 3d printed tires and shocks)
Height	NA (depends on body)
Wheelbase	321mm
Tire Diameter / Width	107mm / 46mm
Wheel Diameter	Outer 56mm, Inner 76mm
Drive Ratio	Gearbox 2.625, Differential 2.5, Total 6,5625
Differential	Front & rear 3d printed open type
Drive	Shaft driven
Theoretical Steering Angle	Max. 30° (depends on the servo angle. 180° servo may steer upto around 27°)
Caster	15° Positive
Camber	Neutral
Toe	Front Zero, Rear 2.5° Toe-in
Battery Compartment Dim.	122x40x43mm
ESC Compartment Dim.	(122 – Motor Body Length)x40x43mm
Motor Mount	Suitable for $\Phi$ 36mm brushless or 540/550 brushed motor (Max motor body length 78mm)
Recommended Motor	Brushless 2600KV or lower KV / Brushed 35T or higher turns
Servo Mount Dimensions	40x20mm servo, distance between mount holes 49x10mm

## NEEDED TOOLS

- PH1 Screw Driver
- 5.5 and 7mm Wrench
- 2.5mm Allen Wrench (A short and a long one with ball head is recommended)
- 7mm Socket Wrench (for tightening wheel nuts)
- Drill & 2.5, 3, 4mm drill Bits
- M3 Tap (Optional. There are only a few screws that are directly screwed on plastic.)
- 200 grit sand paper (For cleaning the bearing fit surfaces)
- Hacksaw (for cutting 3mm rod to length)

## CONSUMABLES

- PLA filament (more than 1 kg)
- PA12 filament (optional)
- TPU filament
- CA glue
- NLGI00 grade lithium grease<sup>(\*)</sup>

(\*) NLGI grade determines the viscosity of the grease. 00 grade is low viscous. While NLGI3 grease is like a soap, NLGI00 is like thin jam. It is mainly used in machines with automatic oil pumps for lubricating the linear rails, gears and bearings. It would be hard (at least in Turkey) to find it in small volumes. It is sold in barrels or buckets. But you can produce your own low viscosity grease by mixing a small amount NLGI 2-3 lithium grease with general purpose machine oil or engine oil. The thickness should be like jam. You can use the same mixture to lubricate the linear rails and linear bearings of the 3d printer.

## NON-PRINTED PARTS BOM

ITEM NO.	PART	SPECIFICATION	QTY
82	motor		1
102	servo		1
126	esc		1
4/15/37/62/83/117	6700 - 15x10x4 bearing		18
13	6802 - 15x24x5 bearing		4
	Φ3mm steele rod		1 meter
30	wheel-shaft-strength-bar	Φ3mm x 60mm	4
91	drive-shaft-strength-bar	Φ3mm x 160mm	1
2	planet-gear-pin	Φ3mm x 28mm	12
24	shock-pin	Φ3mm x 40mm	4
105	rod-ball / 8mm metal bead with 3mm hole		4
7/115	countersunk flat head cross recess screw_iso	M3 X 30	9
103	countersunk flat head cross recess screw_iso	M3 X 10	1
114/138	countersunk flat head cross recess screw_iso	M3 X 12	5
113	countersunk flat head cross recess screw_iso	M3 X 16	2
19/112	countersunk flat head cross recess screw_iso	M3 X 25	6
86/122	countersunk flat head cross recess screw_iso	M3 X 8	10
8/18/52/88/109/129/143/148	hex nut style 1 gradeab_iso	M3	81
57	hex nut style 1 gradeab_iso	M4	8
55/72	hex screw gradeab_iso	M4 X 30	4
48	pan head cross recess screw_iso	M4 X 16	8
43/79	pan head cross recess screw_iso	M4 X 35	4
58/78	pan head cross recess screw_iso_2	M4 X 45	8
10/42/75/96/107	plain washer normal grade a_iso	3	62
41/71	plain washer normal grade a_iso	4	29
20/94/108/127	socket head cap screw_iso	M3 X 10	23
54/74/89/97/123/130/142/147	socket head cap screw_iso	M3 X 12	38
28/51/76/99	socket head cap screw_iso	M3 X 16	17
139	socket head cap screw_iso	M3 X 20	6
45/77	socket head cap screw_iso	M3 X 25	6
44	socket head cap screw_iso	M3 X 30	2
87	socket set screw cup point_iso	M4 X 5	1
9/29/46/121	torque nut o8_iso	M3	31
47/73	torque nut o8_iso	M4	16

Use any 540/550 sized 35T or higher turn brushed motor or any 2600KV or lower KV Φ36mm inrunner brushless motor. (<https://www.aliexpress.com/item/32964687978.html>)

For rod balls, stainless steel beads for jewelry making may be used or the balls can be printed. STL for the rod balls can be found at extras folder. (<https://www.aliexpress.com/item/33012805327.html>)

Links are given for information. Do not consider them as best option.

PRINTED PARTS BOM & PRINT SETTINGS

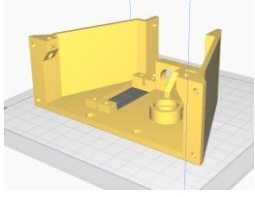
ITEM NO.	PART	QTY	LAYER HEIGHT	S	INFILL	WALL THICKNESS	MAT.	ORIENTATION
36/63	axle	4	0,2mm	N	10	3,2mm	PLA	
110	chassis-front	1	0,3mm	N	10	1,6mm	PLA	
93	chassis-middle	1	0,3mm	N	10	1,6mm	PLA	
60	control-arm-lower-BACK	2	0,2mm	N	10	3,2mm	PLA	
70	control-arm-lower-bracket-back-left	1	0,2mm	N	10	3,2mm	PLA (PA12)	
69	control-arm-lower-bracket-back-right	1	0,2mm	N	10	3,2mm	PLA (PA12)	
49	control-arm-lower-bracket-front-left	1	0,2mm	N	10	3,2mm	PLA (PA12)	
50	control-arm-lower-bracket-front-right	1	0,2mm	N	10	3,2mm	PLA (PA12)	

ITEM NO.	PART	QTY	LAYER HEIGHT	S	INFILL	WALL THICKNESS	MAT.	ORIENTATION
34	control-arm-lower-FRONT	2	0,2mm	N	10	3,2mm	PLA	
65	control-arm-upper-BACK	2	0,2mm	N	10	3,2mm	PLA (PA12)	
39	control-arm-upper-FRONT	2	0,2mm	N	10	3,2mm	PLA (PA12)	
128	cover-front	1	0,3mm	N	10	1,6mm	PLA	
131	cover-middle	1	0,3mm	Y	10	1,6mm	PLA	
1	differential-housing-a	2	0,2mm	N	10	3,2mm	PLA	
6	differential-housing-b	2	0,2mm	N	10	3,2mm	PLA	
11	differential-box	2	0,3mm	N	10	1,6mm	PLA	

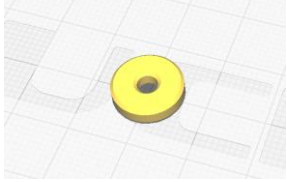

ITEM NO.	PART	QTY	LAYER HEIGHT	S	INFILL	WALL THICKNESS	MAT.	ORIENTATION
14	differential-box-lid	2	0,3mm	N	10	1,6mm	PLA	
16	drive-pinion-gear	2	0,2mm	N	10	3,2mm	PLA	
90	drive-shaft	1	0,2mm	N	10	3,2mm	TPU	
80	gear-box	1	0,3mm	N	10	1,6mm	PLA	
81	gear-box-lid	1	0,3mm	N	10	1,6mm	PLA	
61	knuckle-rear	2	0,2mm	N	10	3,2mm	PLA	
100	lock-bar	1	0,2mm	N	10	1,6mm	PLA	
3	planet-gear	12	0,2mm	N	10	3,2mm	PLA	

ITEM NO.	PART	QTY	LAYER HEIGHT	S	INFILL	WALL THICKNESS	MAT.	ORIENTATION
25	rim	4	0,25mm	Y	10	1,6mm	PLA	
116	rod-ball-spacer	2	0,2mm	N	10	1,6mm	PLA	
111	servo-cover	1	0,3mm	N	10	1,6mm	PLA	
104	servo-saver	1	0,2mm	N	10	3,2mm	PLA	
119	servo-saver-SLAVE	1	0,2mm	N	10	3,2mm	PLA	
118	servo-saver-washer	1	0,2mm	N	10	1,6mm	PLA	
84	sg-16-1	1	0,2mm	N	10	3,2mm	PLA	
85	sg-42-1	1	0,2mm	N	10	3,2mm	PLA	

ITEM NO.	PART	QTY	LAYER HEIGHT	S	INFILL	WALL THICKNESS	MAT.	ORIENTATION
5	shaft-gear	4	0,2mm	N	10	3,2mm	PLA	
23	shock-eye-A	4	0,2mm	N	10	3,2mm	PLA	
22	shock-eye-B	4	0,2mm	N	10	3,2mm	PLA	
66	shock-tower-back	1	0,3mm	N	10	1,6mm	PLA	
53	shock-tower-front	1	0,3mm	Y	10	1,6mm	PLA	
120	steering-center-link	1	0,2mm	N	10	3,2mm	PLA	
33	steering-knuckle-bracket	4	0,2mm	N	10	3,2mm	PLA	
32	steering-knuckle-left	1	0,2mm	N	10	3,2mm	PLA	

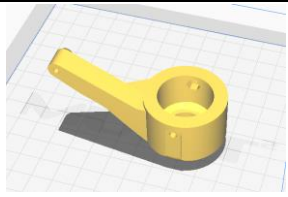
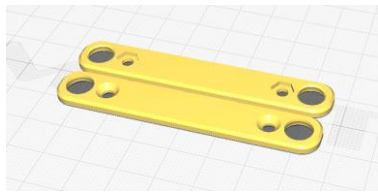
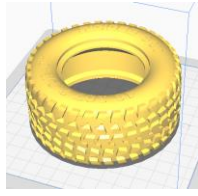
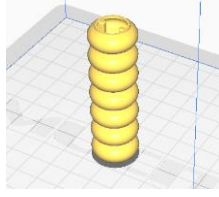
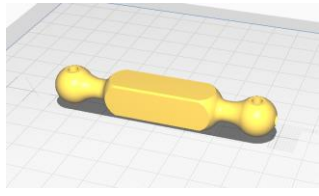
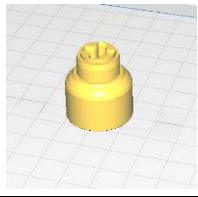
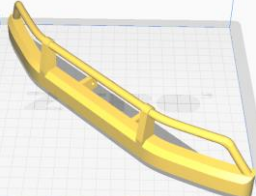
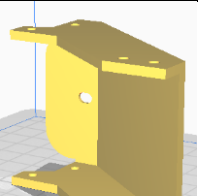
ITEM NO.	PART	QTY	LAYER HEIGHT	S	INFILL	WALL THICKNESS	MAT.	ORIENTATION
56	steering-knuckle-right	1	0,2mm	N	10	3,2mm	PLA	
106	steering-linkage(*)	2	0,2mm	N	10	3,2mm	PLA	
26	tire	4	0,25mm	N	10	1,6mm	TPU	
21	tpu-spring	4	0,2mm	N	10	1,6mm	TPU	
27	wheel-shaft	4	0,2mm	N	10	3,2mm	PLA	
17	wheel-shaft-housing	4	0,2mm	N	10	3,2mm	PLA	
140	bumper-bottom-front	1	0,3mm	Y	10	2mm	PLA	
141	bumper-bracket-front	1	0,3mm	Y	10	2mm	PLA	

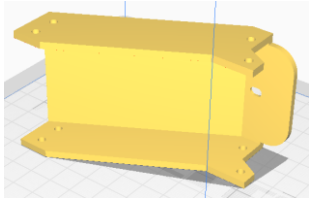
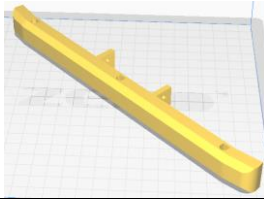
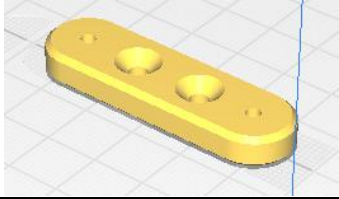
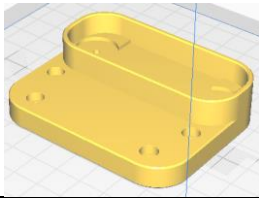
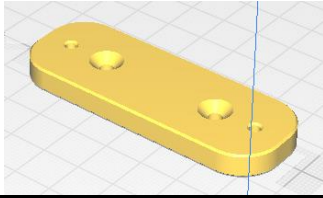
ITEM NO.	PART	QTY	LAYER HEIGHT	S	INFILL	WALL THICKNESS	MAT.	ORIENTATION
144	bumper-rail-back	1	0,2mm	N	10	2mm	PLA	
145	bumper-bracket-back	1	0,3mm	Y	10	2mm	PLA	
146	bumper-bottom-back	1	0,3mm	N	10	2mm	PLA	
132	body-mount-front	1	0,3mm	N	10	2mm	PLA	
133	body-mount-front-body-bracket	1	0,3mm	N	10	2mm	PLA	
134	body-mount-rear	1	0,3mm	N	10	2mm	PLA	
135	body-mount-rear-body-bracket	1	0,3mm	N	10	2mm	PLA	

S: Support Needed? Y=Yes / N=No -- MAT.: Material

Although PLA is sufficient for most of the parts on normal operation of the car. It is seen that some parts tend to break more frequently on crashes. It is recommended to print these parts with a nylon blend such as PA12. PA12 is shown in parenthesis as material for these parts.

(\* ) Print steering linkage in 2 pieces by lowering the model 2.5mm in Z direction into the print bed. Combine 2 halves by screws and nuts after placing the rod balls on the recesses.

## EXPLODED DRAWINGS

### DIFFERENTIAL INNER ASSY

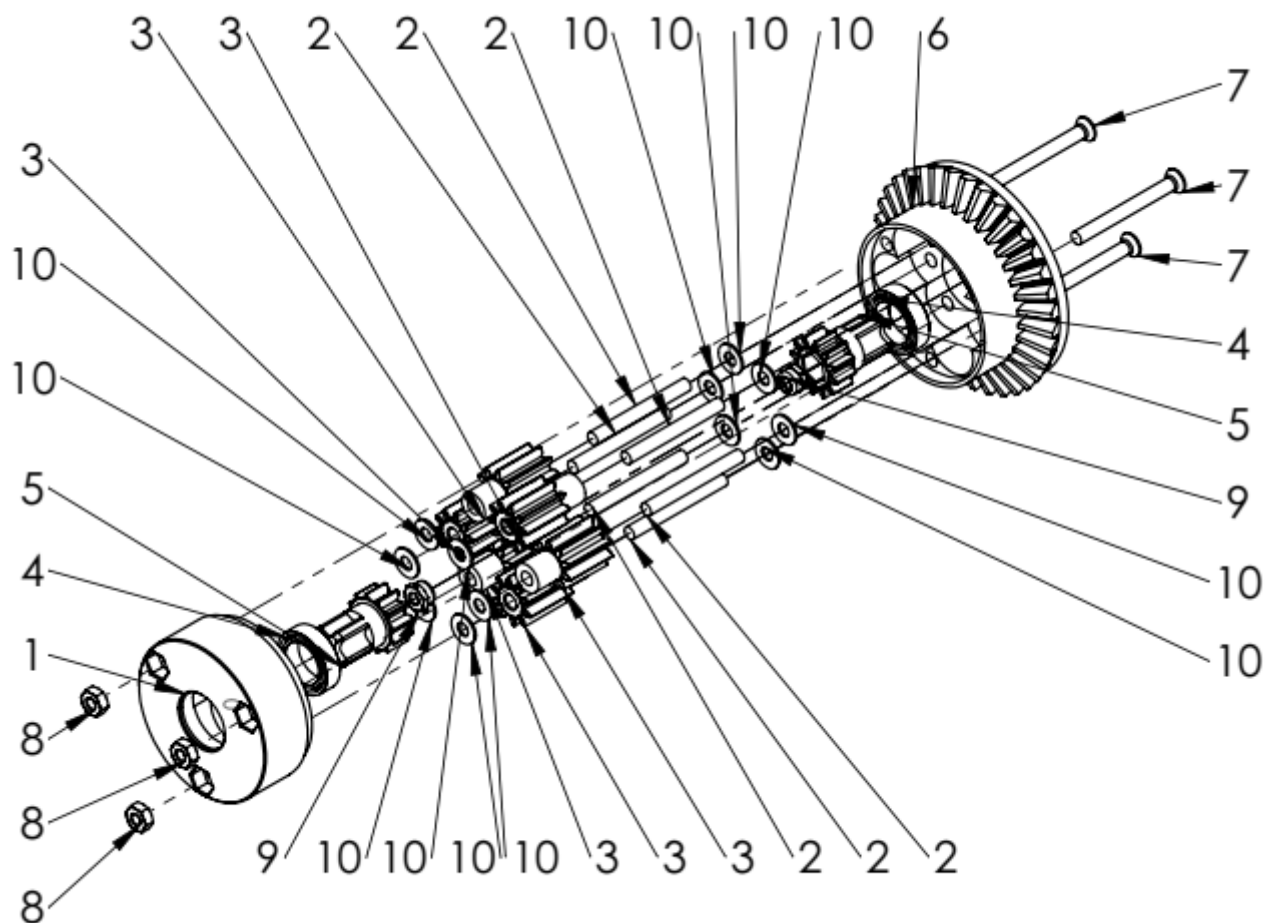

ITEM NO.	PART	SPECIFICATION	QTY.
1	differential-housing-a		1
2	planet-gear-pin	Φ3mm x 28mm	6
3	planet-gear		6
4	6700 - 15x10x4 bearing		2
5	shaft-gear		2
6	differential-housing-b		1
7	countersunk flat head cross recess screw_iso	M3 X 30	3
8	hex nut style 1 grade a_b_iso	M3	3
9	torque nut o8_iso	M3	2
10	plain washer normal grade a_iso	3	12

Note:

Fill the housing with NLG100 grade grease.

## DIFFERENTIAL ASSY

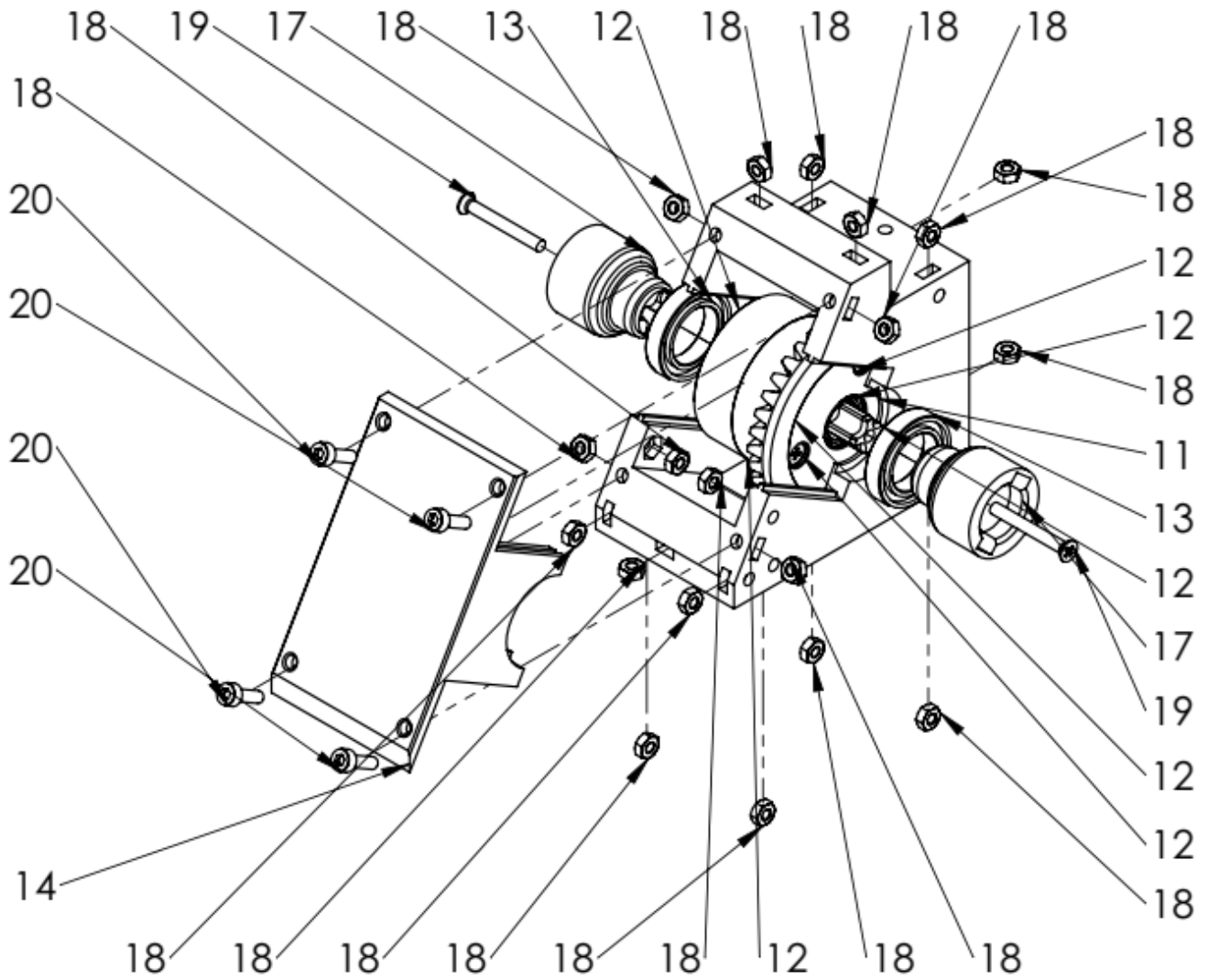

ITEM NO.	PART	SPECIFICATION	QTY.
11	differential-box		1
12	differential-inner-assy		1
13	radial ball bearing_68_iso	15X24X5MM 6802	2
14	differential-box-lid		1
15	6700 - 15x10x4 Bearing		1
16	drive-pinion-gear		1
17	wheel-shaft-housing		2
18	hex nut style 1 gradeab_iso	M3	21
19	countersunk flat head cross recess screw_iso	M3 X 25	2
20	socket head cap screw_iso	M3 X 10	4

Note:

Apply NLG100 grade grease on the bevel gears.

## SHOCK ASSY

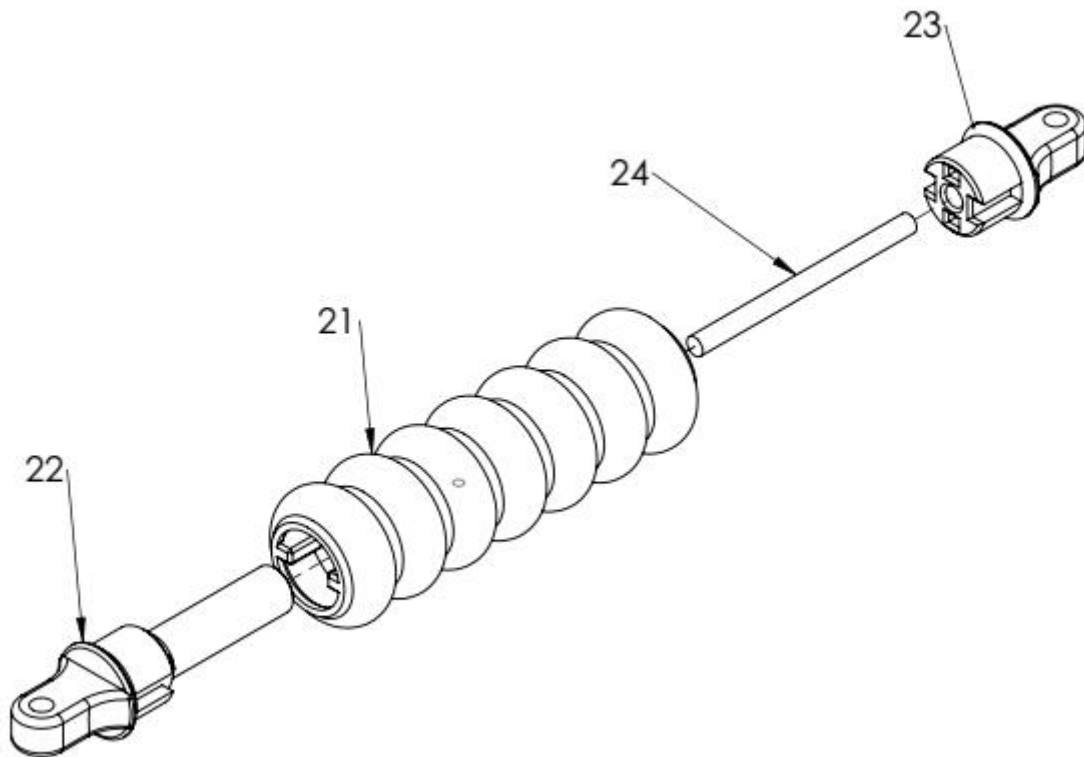

ITEM NO.	PART	SPECIFICATION	QTY.
21	tpu-spring		1
22	shock-eye	B	1
23	shock-eye	A	1
24	shock-pin	Φ3mm x 40mm	1

Note:

Glue the parts. Pin to shock-eye-A. Shock eyes to tpu-spring.



## WHEEL ASSY

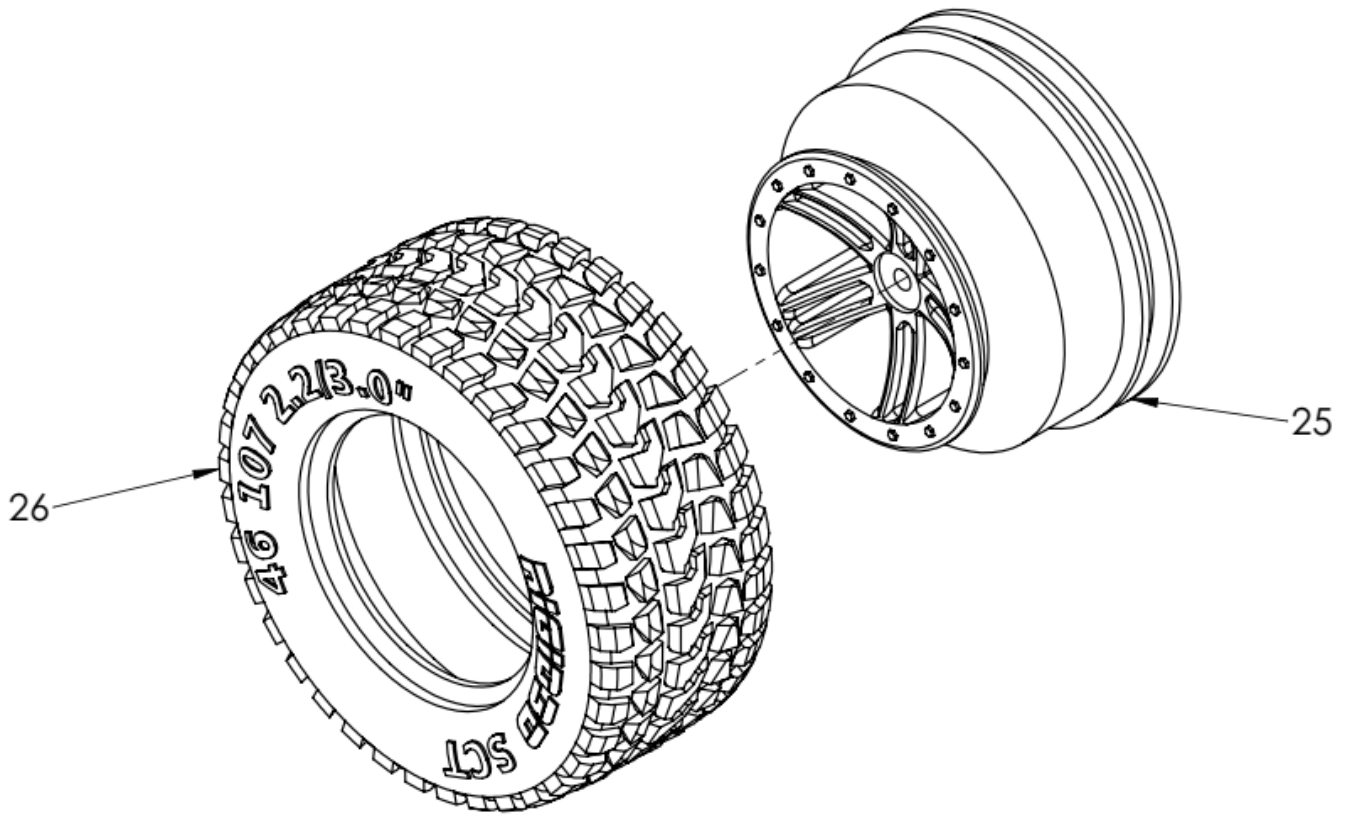

ITEM NO.	PART	SPECIFICATION	QTY.
25	rim		1
26	tire		1

### Notes:

Rim and tire fit very tightly and it requires a lot of force to assemble them together. You may try stepping on the sides of the tire to slide them onto the rim.

## WHEEL SHAFT ASSY

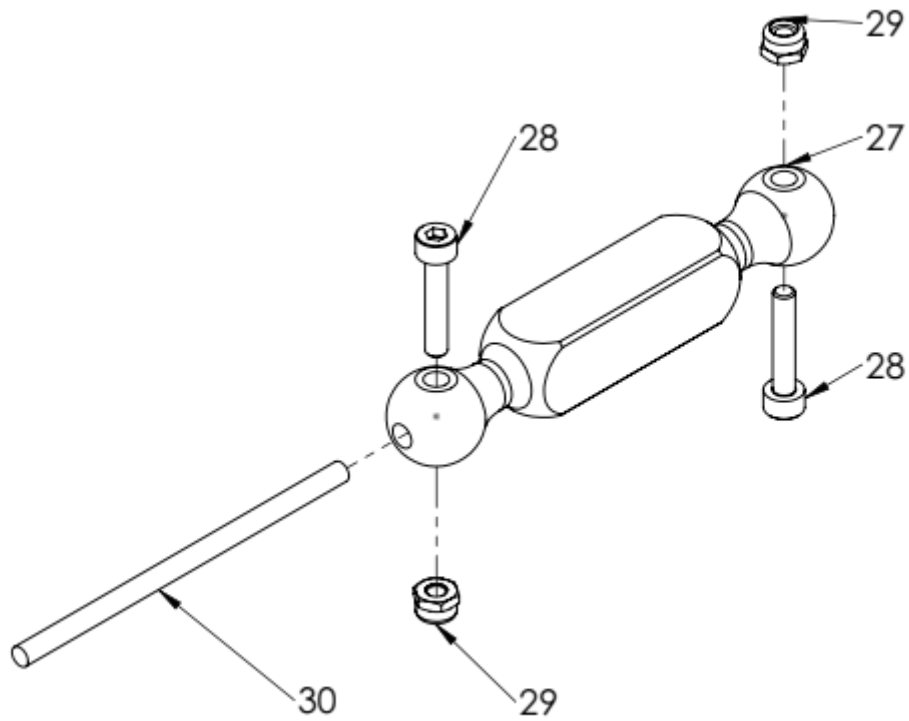

ITEM NO.	PART	SPECIFICATION	QTY.
27	wheel-shaft		1
28	socket head cap screw_iso	M3 X 16	2
29	torque nut 08_iso	M3	2
30	wheel-shaft-strength-bar	Φ3mm x 60mm	1

## FRONT ASSY

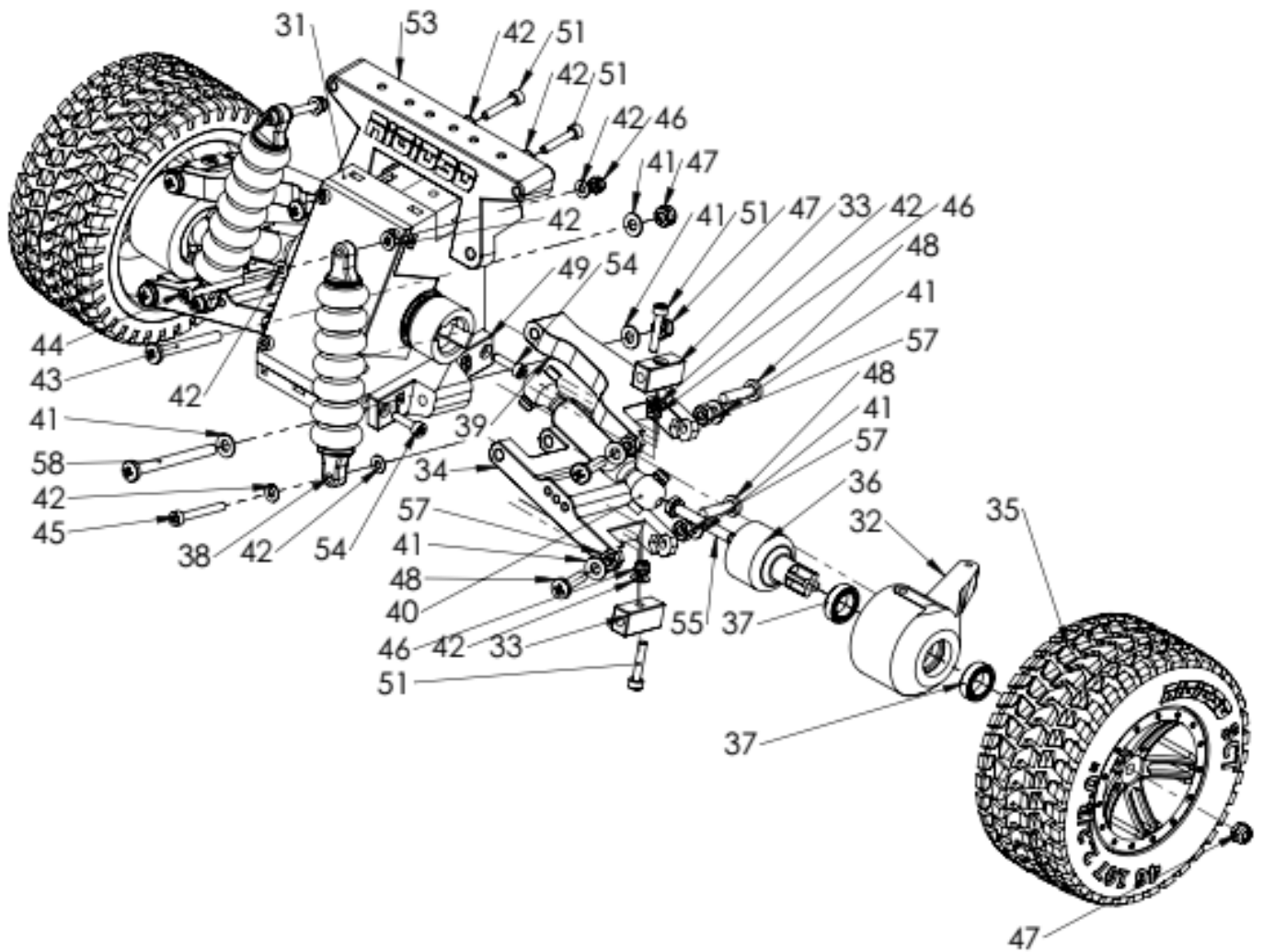

### Notes:

- Only one side is exploded for constraining the sketch size.
- For ease of work, assemble the tires in the last step. Do not install them at this stage of the assembly.

ITEM NO.	PART	SPECIFICATION	QTY.
31	differential-assy		1
32	steering-knuckle-left		1
33	steering-knuckle-bracket		4
34	control-arm-lower-FRONT	FRONT	2
35	wheel-assy		2
36	axle		2
37	6700 - 15x10x4 Bearing		4
38	shock-assy-V2		2
39	control-arm-upper-FRONT	FRONT	2
40	wheel-shaft-assy		2
41	plain washer normal grade a_iso	4	13
42	plain washer normal grade a_iso	3	17
43	pan head cross recess screw_iso	M4 X 35	2
44	socket head cap screw_iso	M3 X 30	2
45	socket head cap screw_iso	M3 X 25	2
46	torque nut o8_iso	M3	6
47	torque nut o8_iso	M4	6
48	pan head cross recess screw_iso	M4 X 16	8
49	control-arm-lower-bracket-front-left		1
50	control-arm-lower-bracket-front-right		1
51	socket head cap screw_iso	M3 X 16	6
52	hex nut style 1 gradeab_iso	M3	2
53	shock-tower-front		1
54	socket head cap screw_iso	M3 X 12	4
55	hex screw gradeab_iso	M4 X 30	2
56	steering-knuckle-right		1
57	hex nut style 1 gradeab_iso	M4	8
58	pan head cross recess screw_iso_2	M4 X 45	2

## BACK ASSY

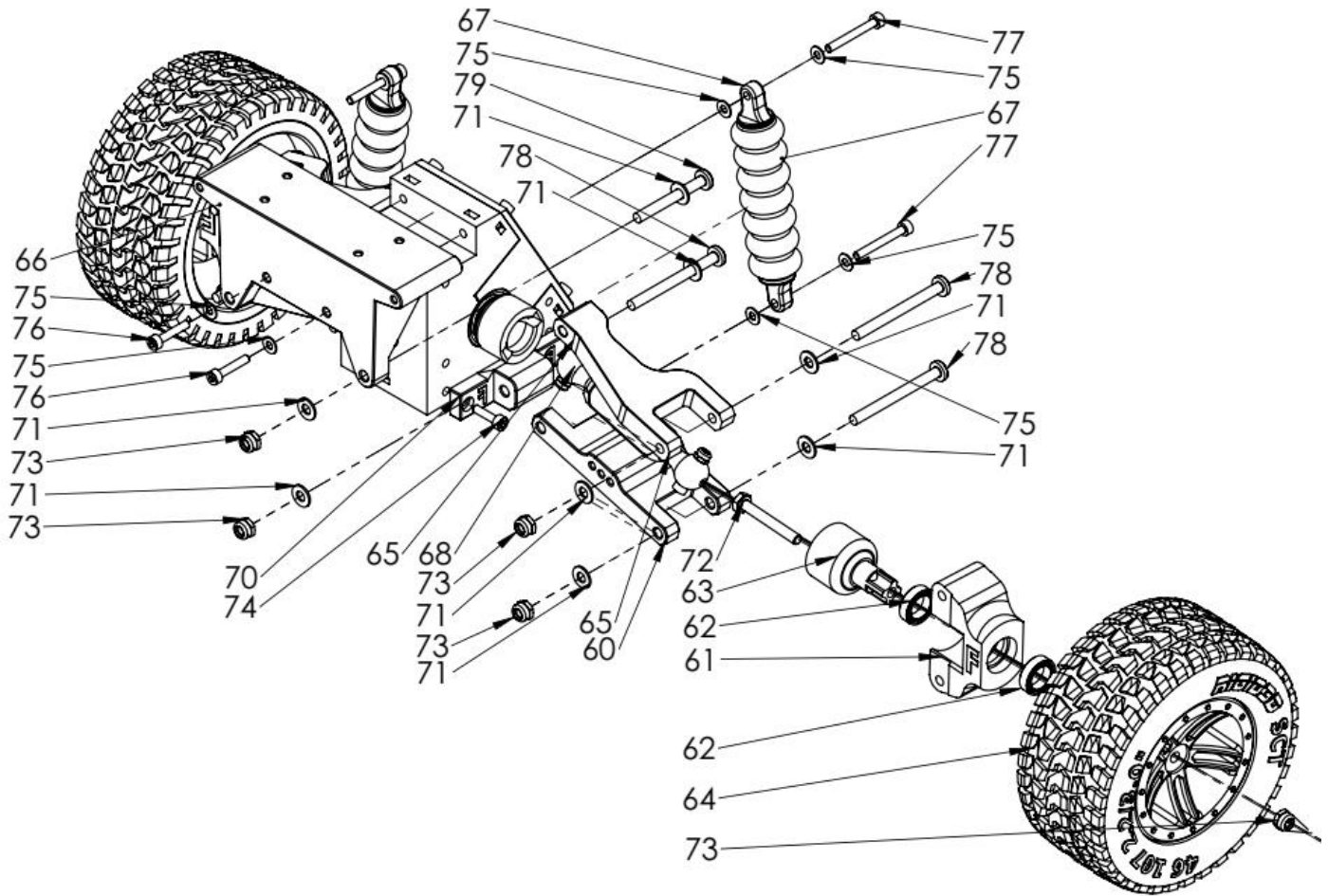

### Notes:

- Only one side is exploded for constraining the sketch size.
- For ease of work, assemble the tires in the last step. Do not install them at this stage of the assembly.

ITEM NO.	PART	SPECIFICATION	QTY.
59	differential-assy		1
60	control-arm-lower-BACK	BACK	2
61	knuckle-rear		2
62	6700 - 15x10x4 Bearing		4
63	axle		2
64	wheel-assy		2
65	control-arm-upper-BACK	BACK	2
66	shock-tower-back		1
67	shock-assy-V2		2
68	wheel-shaft-assy		2
69	control-arm-lower-bracket-back-right		1
70	control-arm-lower-bracket-back-left		1
71	plain washer normal grade a_iso	4	16
72	hex screw gradeab_iso	M4 X 30	2
73	torque nut o8_iso	M4	10
74	socket head cap screw_iso	M3 X 12	4
75	plain washer normal grade a_iso	3	10
76	socket head cap screw_iso	M3 X 16	2
77	socket head cap screw_iso	M3 X 25	4
78	pan head cross recess screw_iso_2	M4 X 45	6
79	pan head cross recess screw_iso_2	M4 X 35	2

## GEAR BOX ASSY

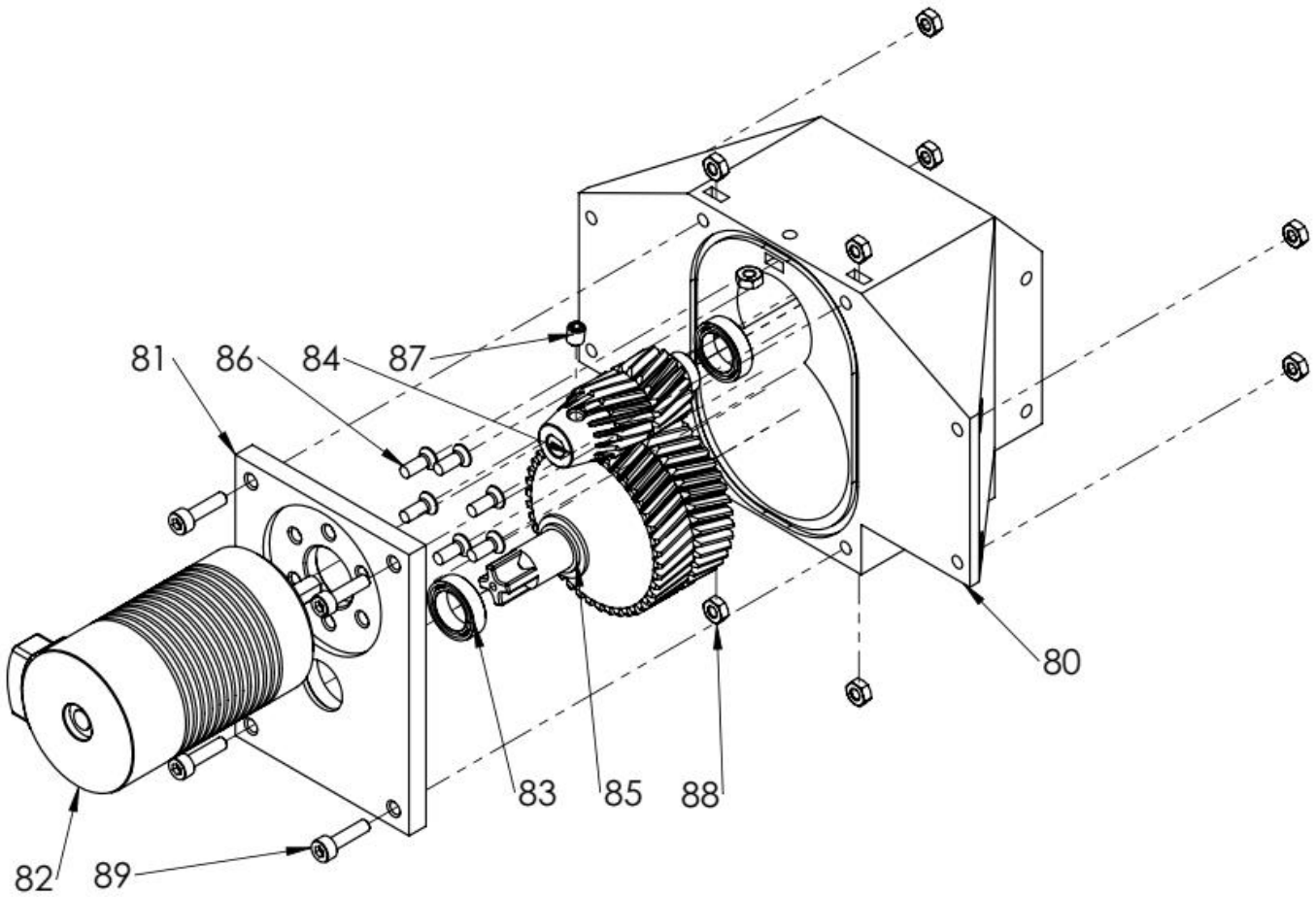

ITEM NO.	PART	SPECIFICATION	QTY.
80	gear-box		1
81	gear-box-lid		1
82	motor		1
83	6700 - 15x10x4 Bearing		2
84	sg-16-1	16T-M1	1
85	sg-42-1	42T-M1	1
86	countersunk flat head cross recess screw_iso	M3 X 8	6
87	socket set screw cup point_iso	M4 X 5	1
88	hex nut style 1 gradeab_iso	M3	9
89	socket head cap screw_iso	M3 X 12	4

Note:

Apply NLG100 grade grease on the gears.

## DRIVE SHAFT ASSY

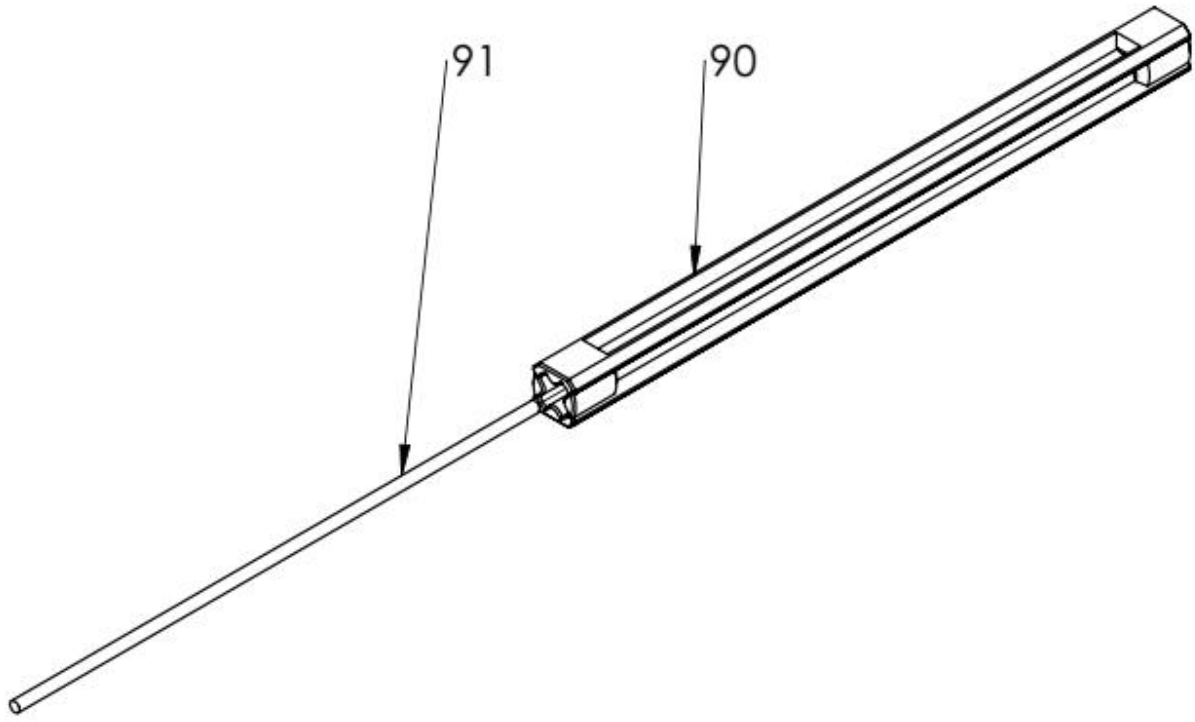

ITEM NO.	PART	SPECIFICATION	QTY.
90	drive-shaft		1
91	drive-shaft-strength-bar	Φ3mm x 160mm	1



## RIGID3D SCT BACK ASSY

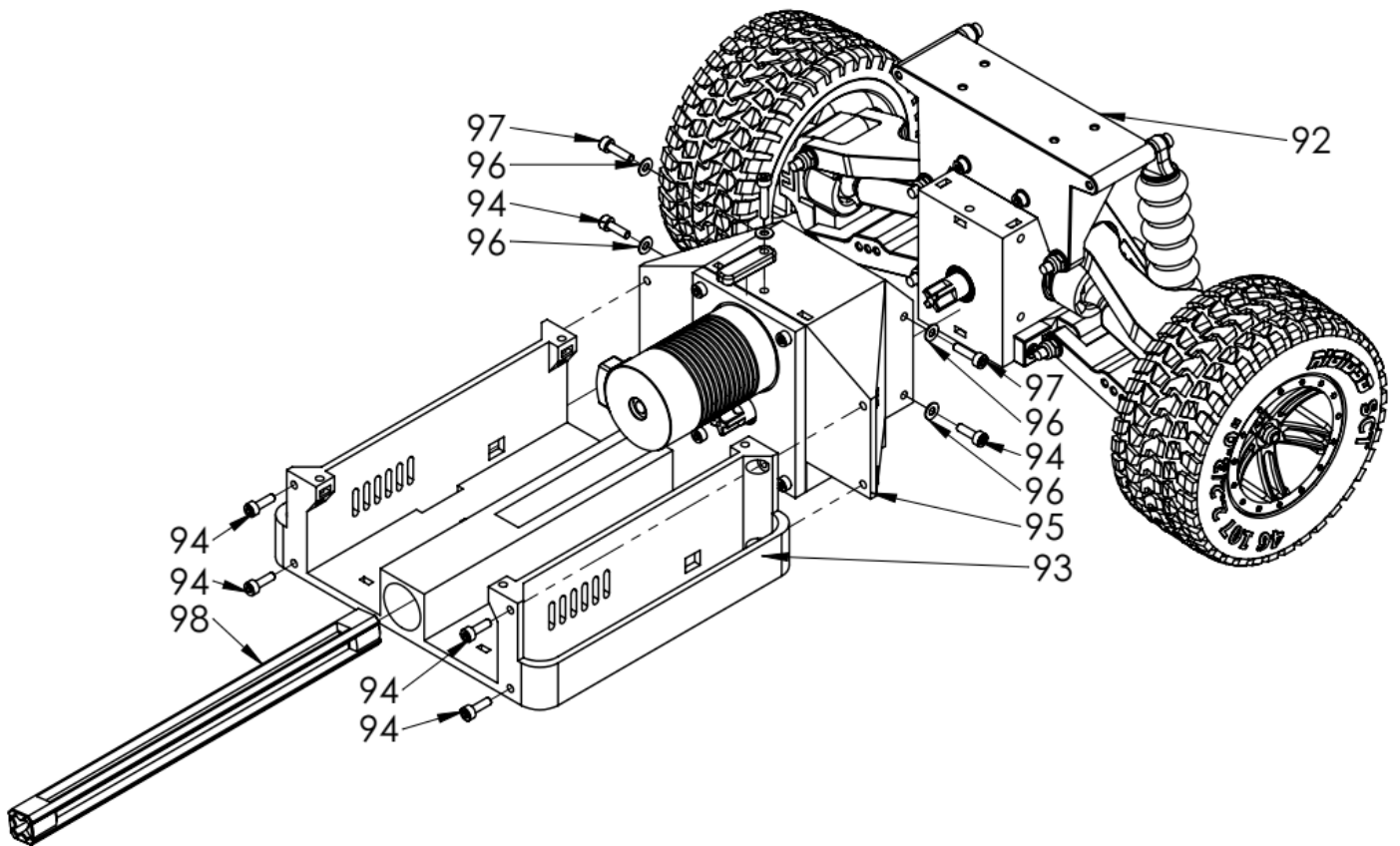

ITEM NO.	PART	SPECIFICATION	QTY.
92	back-assy		1
93	chassis-middle		1
94	socket head cap screw_iso	M3 X 10	6
95	gear-box-assy		1
96	plain washer normal grade a_iso	3	5
97	socket head cap screw_iso	M3 X 12	2
98	drive-shaft-assy		1
99	socket head cap screw_iso	M3 X 16	1
100	lock-bar		1

RIGID3D SCT FRONT ASSY

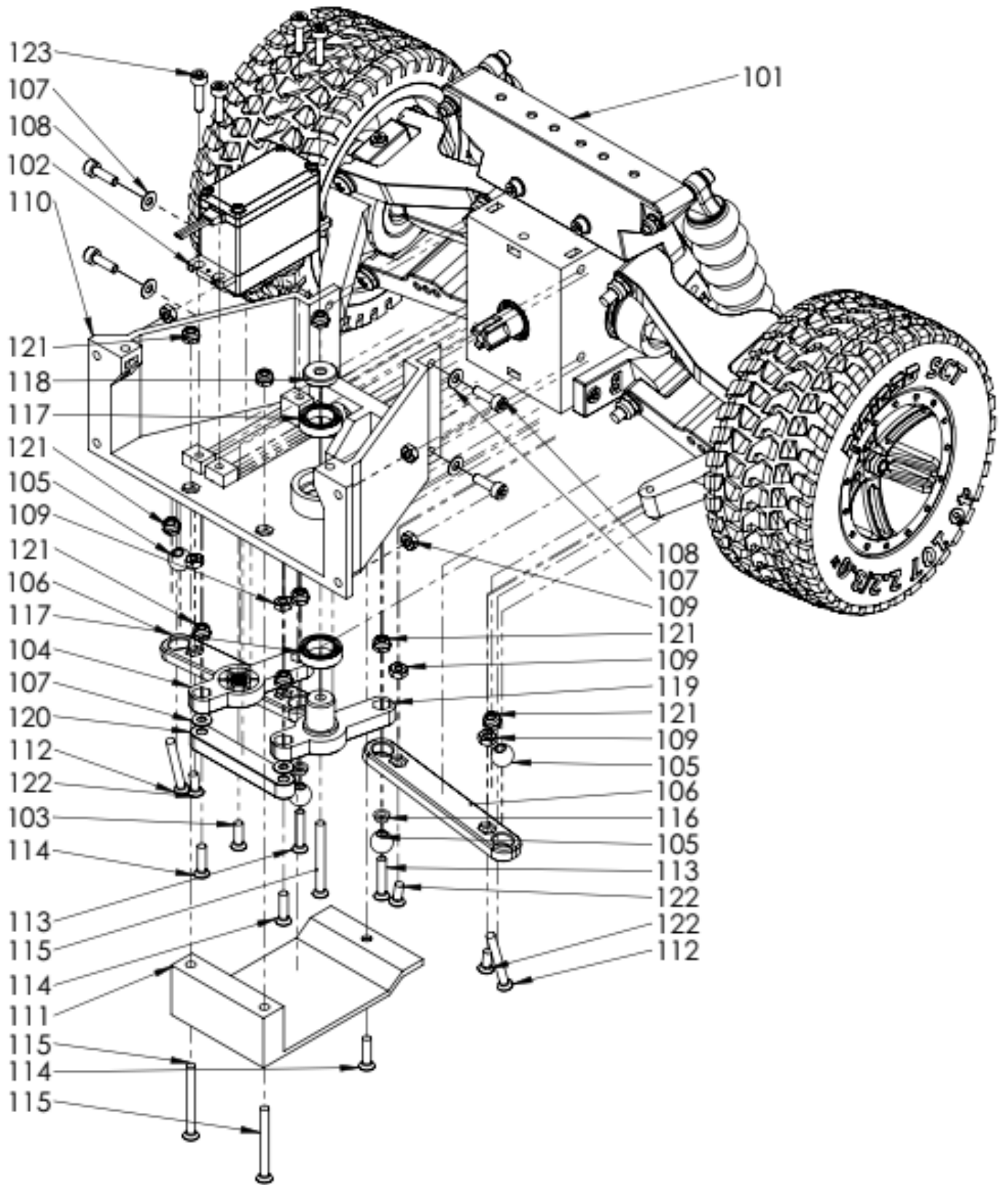

ITEM NO.	PART	SPECIFICATION	QTY.
101	front-assy		1
102	servo		1
103	countersunk flat head cross recess screw_iso	M3 X 10	1
104	servo-saver		1
105	rod-ball		4
106	steering-linkage		2
107	plain washer normal grade a_iso	3	6
108	socket head cap screw_iso	M3 X 10	4
109	hex nut style 1 gradeab_iso	M3	8
110	chassis-front		1
111	servo-cover		1
112	countersunk flat head cross recess screw_iso	M3 X 25	2
113	countersunk flat head cross recess screw_iso	M3 X 16	2
114	countersunk flat head cross recess screw_iso	M3 X 12	3
115	countersunk flat head cross recess screw_iso	M3 X 30	3
116	rod-ball-spacer		2
117	6700 - 15x10x4 Bearing		2
118	servo-saver-washer		1
119	servo-saver-SLAVE	SLAVE	1
120	steering-center-link		1
121	torque nut o8_iso	M3	13
122	countersunk flat head cross recess screw_iso	M3 X 8	4
123	socket head cap screw_iso	M3 X 12	4

## RIGID3D SCT V2

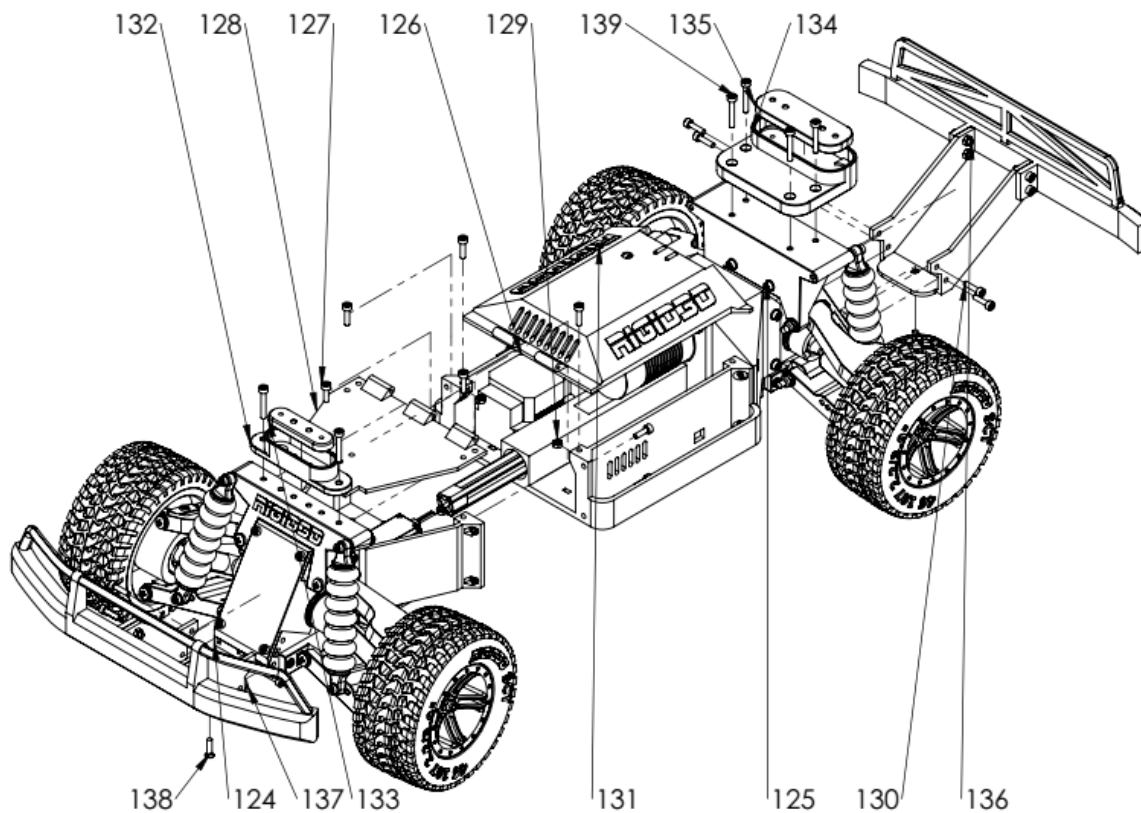

ITEM NO.	PART	SPECIFICATION	QTY.
124	rigid3d-sct-front-assy		1
125	rigid3d-sct-back-assy		1
126	esc		1
127	socket head cap screw_iso	M3 X 10	5
128	cover-front		1
129	hex nut style 1 gradeab_iso	M3	6
130	socket head cap screw_iso	M3 X 12	12
131	cover-middle		1
132	body-mount-front		1
133	body-mount-front-body-bracket		1
134	body-mount-rear		1
135	body-mount-rear-body-bracket		1
136	bumper-back		1
137	bumper-front		1
138	countersunk flat head cross recess screw_iso	M3 X 12	2
139	socket head cap screw_iso	M3 X 20	6

Note:

Middle cover is hinged. Use a piece of 1.75mm filament as hinge pin.

## BUMPER FRONT

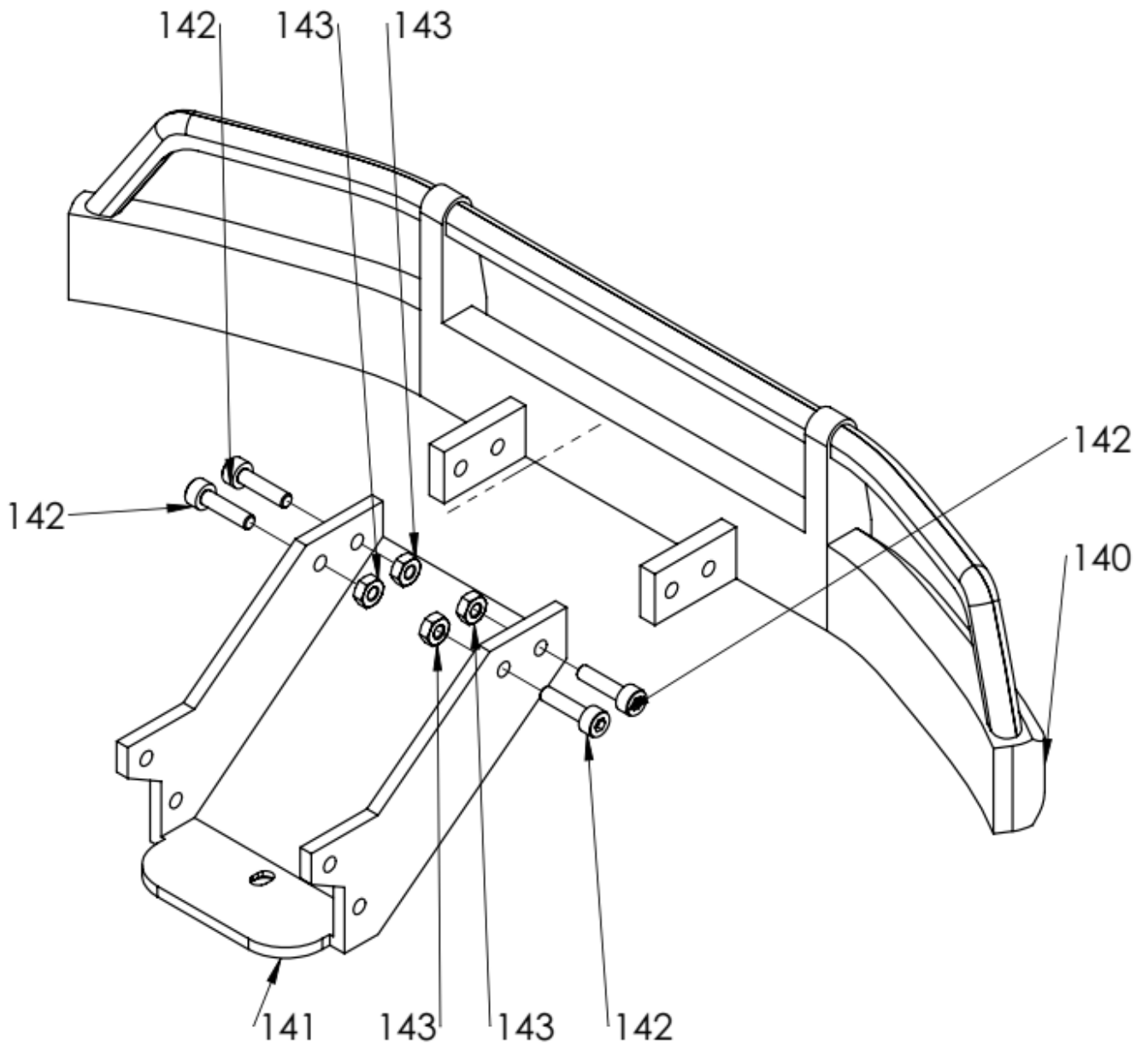

ITEM NO.	PART	SPECIFICATION	QTY.
140	bumper-bottom-front		1
141	bumper-bracket-front		1
142	socket head cap screw_iso	M3 X 12	4
143	hex nut style 1 gradeab_iso	M3	4

## BUMPER BACK

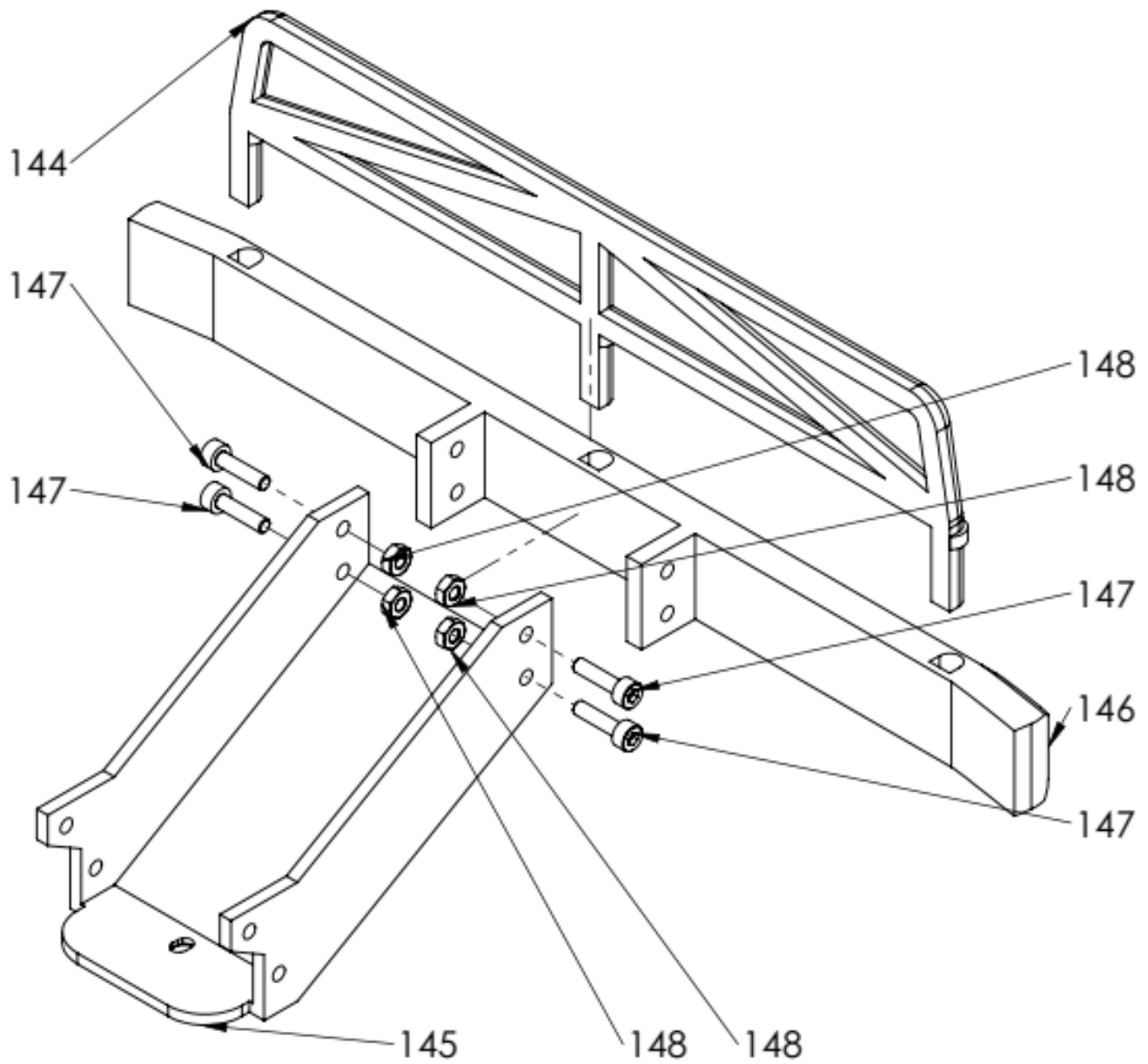

ITEM NO.	PART	SPECIFICATION	QTY.
144	bumper-rail-back		1
145	bumper-bracket-back		1
146	bumper-bottom-back		1
147	socket head cap screw_iso	M3 X 12	4
148	hex nut style 1 gradeab_iso	M3	4