

Railbike Chassis Assembly

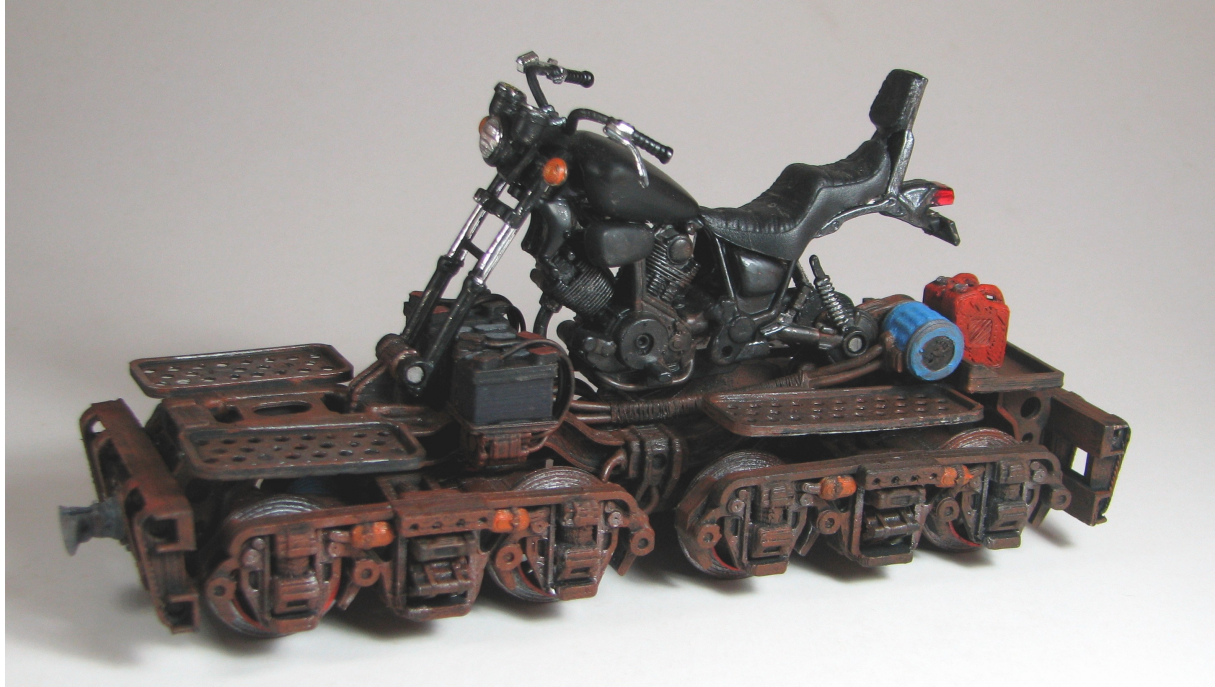

This chassis is designed to suit a 1:18 scale Harley Davidson¹ model from Maisto. It could be adapted easily to other motorbike models. The important thing to note here is that **THE MOTORBIKE IS NOT 3D PRINTED**, just in case you were thinking “Wow! Cool motorbike model”. What you are getting with this model is the railway chassis and everything shown except the motorbike. There are some other very nice motorbike models on Thingiverse that could be adapted to work with this chassis. The image below shows the 3D printed model bits.

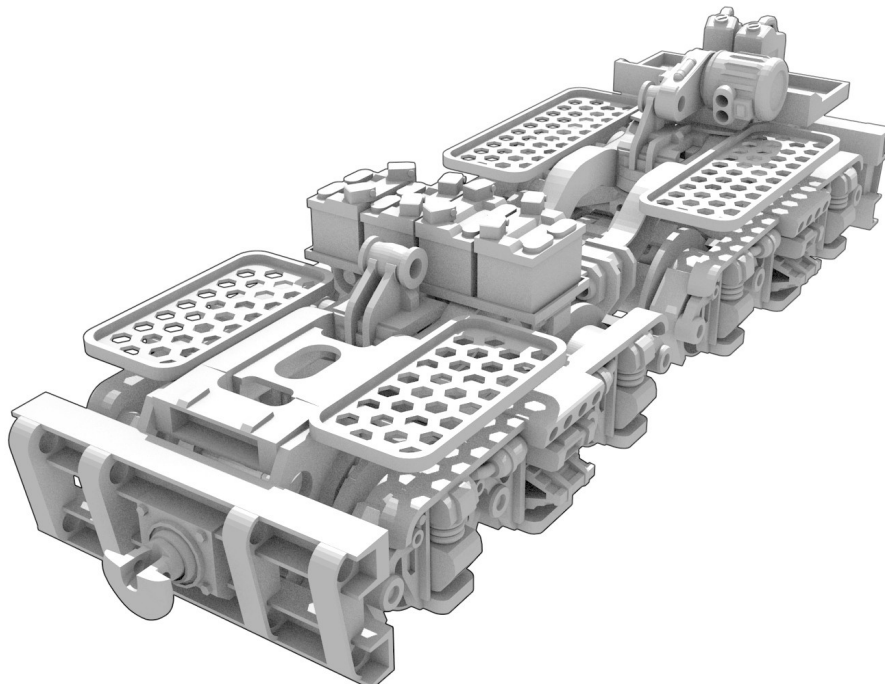

1 Or at least, I think it is a Harley Davidson.

3D Printed Railbike Chassis Assembly Instructions

You will find the model files are all of the format "3DPrintedRailbike-Blahblahblahx4.stl" where the last bit is the number of that item you will need to print. So yep, you can expect quite a pile of pieces by the end of your printing session. None of the pieces require support.

The extra bits you will need are;

- a pair of M4 machine screws and a nut. You may like to include a washer.
- some $\varnothing 4\text{mm}$ dowels 54mm long (or anything else you can use of an axle)
- a short $\varnothing 4\text{mm}$ dowel to pin the two sides of the deck spine together
- hook up wire and any wire about $\varnothing 2\text{mm}$ for the cables
- some $\varnothing 3$ rod of some sort to pin the motorbike model to the locations on the deck. I used some bits of old nail.
- Your chosen motorbike model

There are two stages in the assembly; the bogies, and the deck.

Assembling the Bogies

Step 1

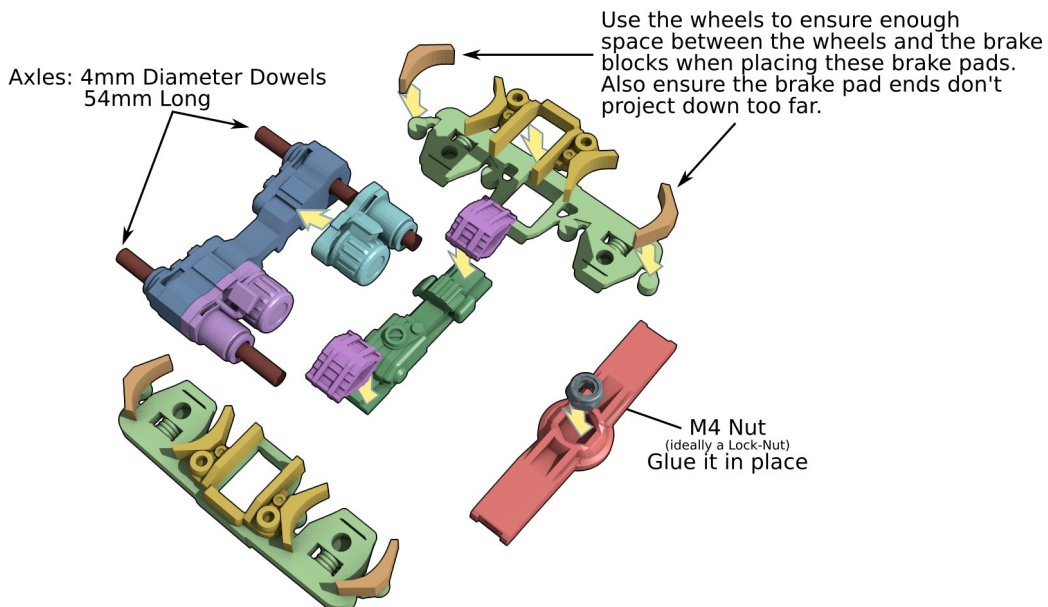

Step 2

Slide the wheels onto the $\varnothing 4\text{mm}$ 54mm long dowels, and allow sufficient to stick out where it can engage with the recesses on the side panels. This is typically 4.5mm each side

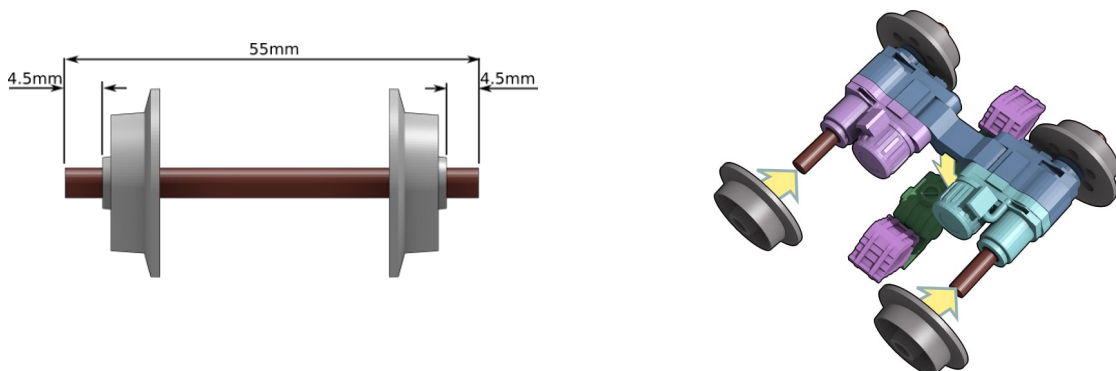

3D Printed Railbike Chassis Assembly Instructions

Step 3

Drop the upper cross piece down onto the leaf springs and slide the side pieces into place.

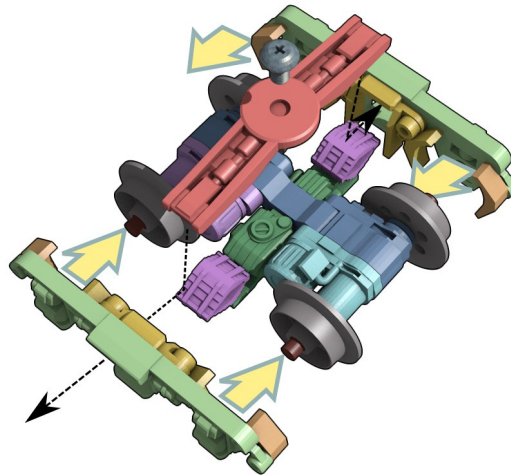

Step 4

Well, actually there is no step 4. This is just to illustrate how the assembled bogie should look.

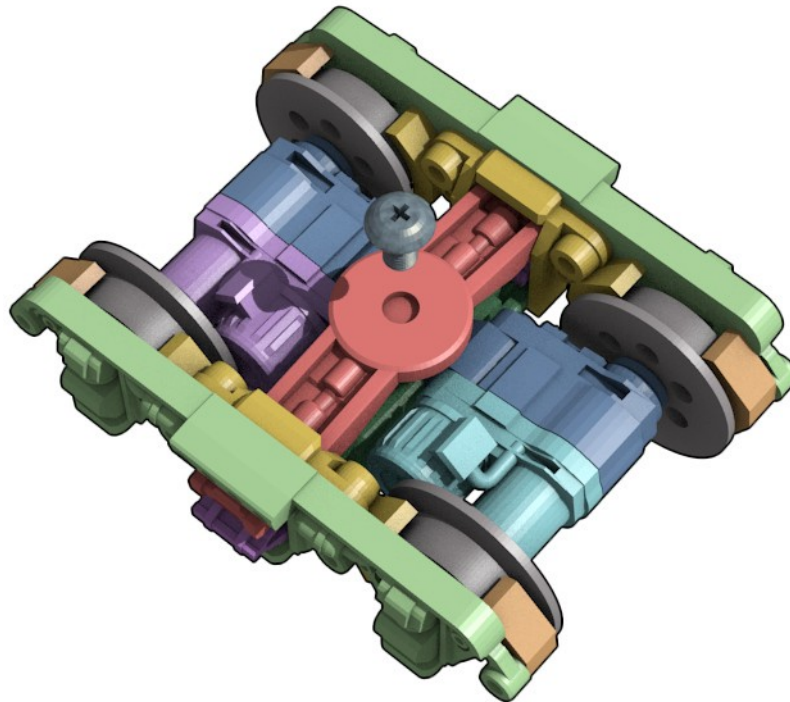

And now, do it all again on the second one.

Assembling the Deck

STEP 1

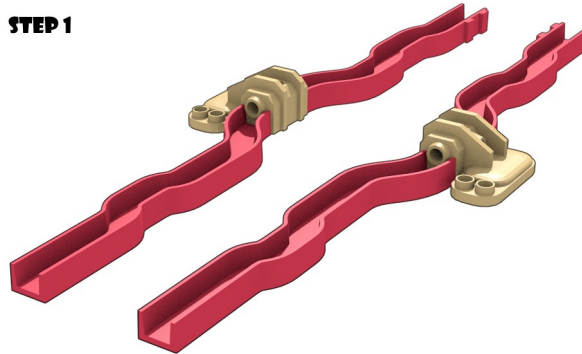

On a good flat surface glue the side rails onto the Undermass Left and Right components. Just be aware which way the wobbles go and where the two lugs on the back of the “UnderbarsBack” components are. It will pay to use a straight edge along what will be the top surface of the “Underbars” to ensure the deck is glued straight.

STEP 2

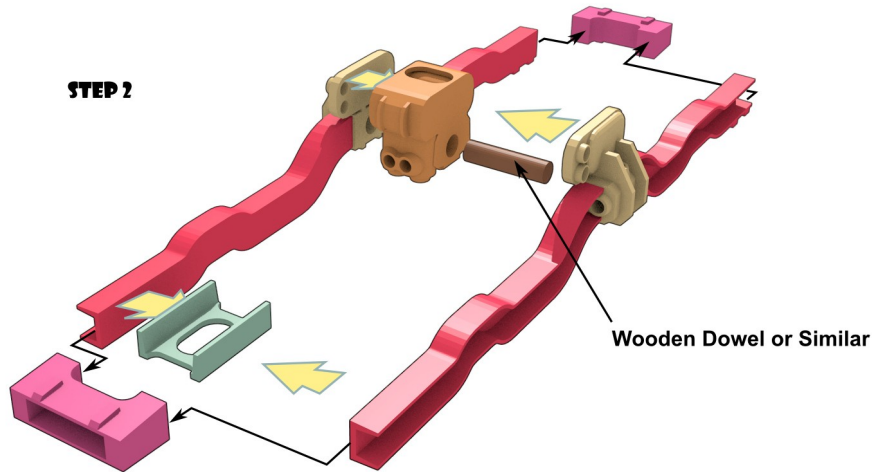

Use the small $\varnothing 4\text{mm}$ dowel stub to help locate the two side sections. Glue the endcaps and FrontWeb in place.

STEP 3

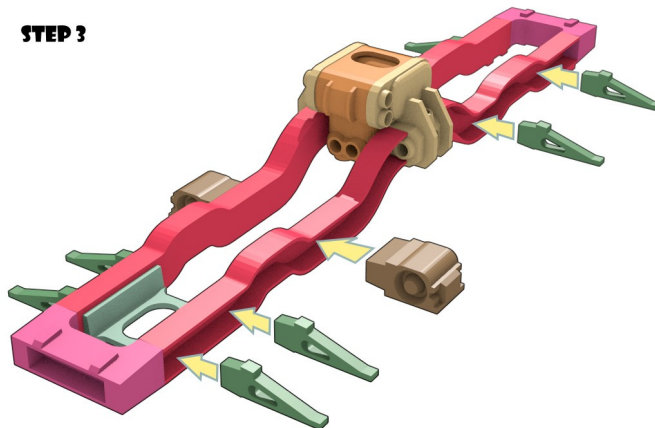

Add the footplate supports and the two battery tray terminal blocks. To make things easy, lay the assembly on its back as shown and pack up the footplate supports with some cardboard so they are sitting flat.

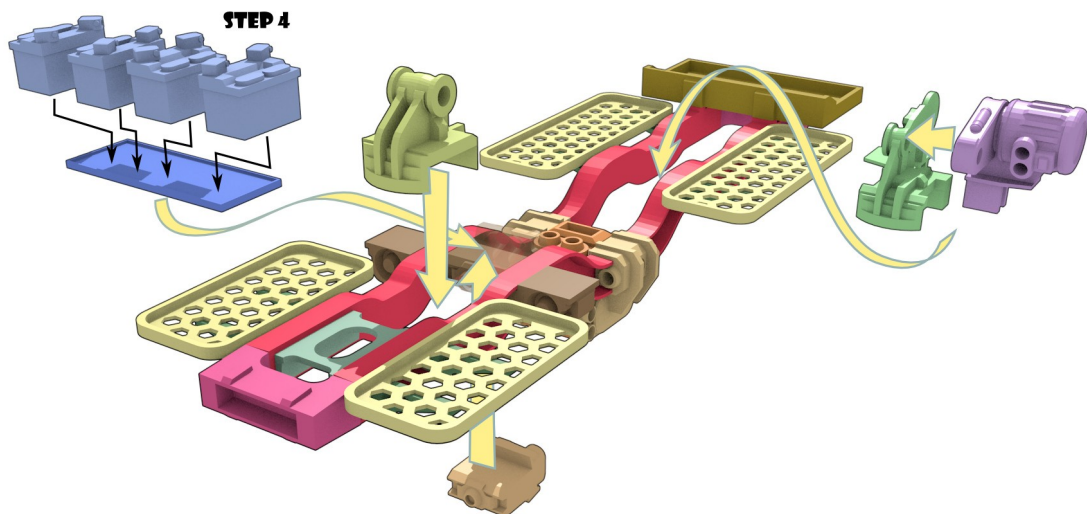

Add the batteries to the battery tray making sure you have the battery terminals around the right way. It may pay to clear the recesses in the battery terminals at this stage which you still have easy access with a drill. Put the “Charge Controller” component in place with the larger flat top surface flush with the top of the assembly. Add the footplates. Glue the “Generator” section to the Back Hub cap. Add the back tray too. Before gluing on the battery tray and the front and back hubcap assemblies, check the fit with your motorbike model. You will probably need to slide the battery tray around a bit to get it to fit depending on the type of model you are using. When you are satisfied with the fit, glue them in place.

STEP 5

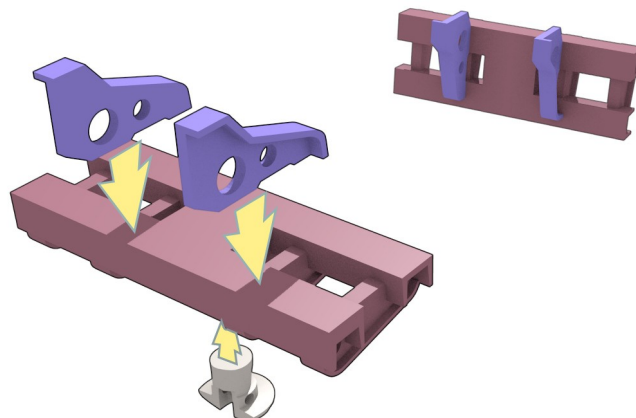

Assemble the two buffers. Use the deck assembly to ensure the spacing between the webs is correct.

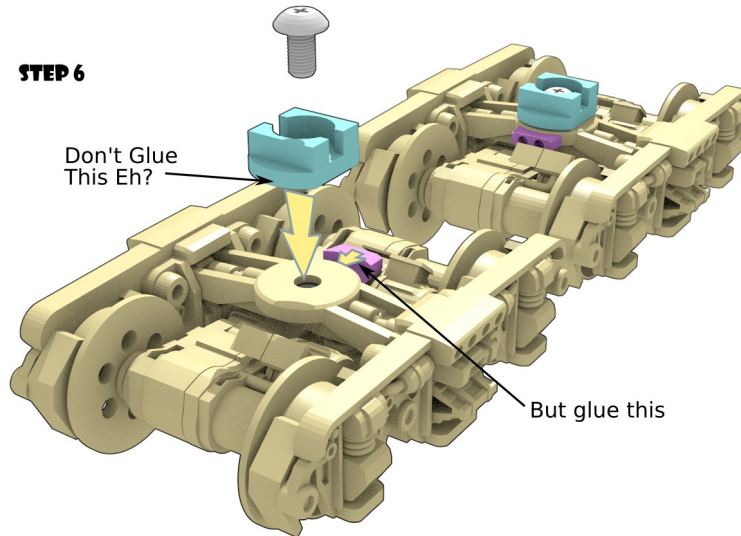

With your two bogies in hand, add the two bogie wire terminals. These are where your wires will connect. The two bogie hubs can be installed. These are not glued. Leave a little looseness in the screws so the bogie pivot will turn. It is probably worth adding a washer in between the bogie and the bogie hub to allow smooth rotation.

The bogies should clip up into the front and back hubcaps which are now mounted in the deck assembly. There is no need to glue this in place.

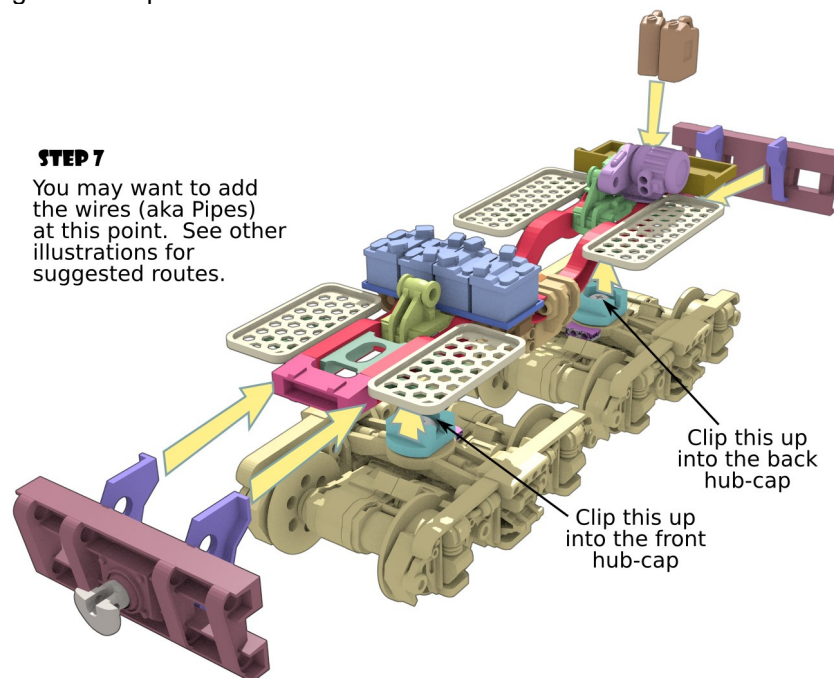

With the bogies installed and the assembly sitting on rails or at least something that will allow it to sit as it would on rails, glue the buffers in place allowing space below them so they're not dragging on the ground. Don't slide them too close to the bogies either, you still want the bogies to be able to swivel a bit. Add the wires to simulate the cable routes. Below are the routes I used on mine.

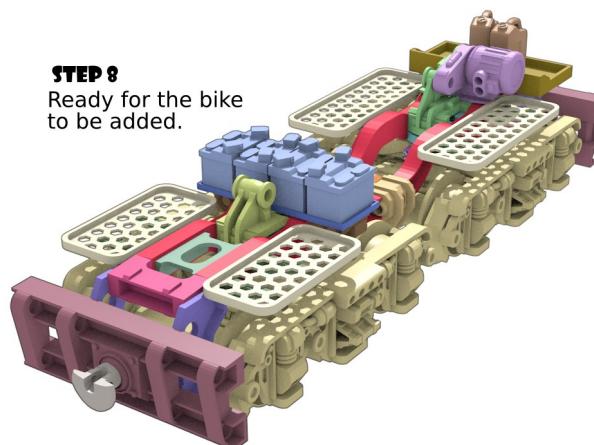
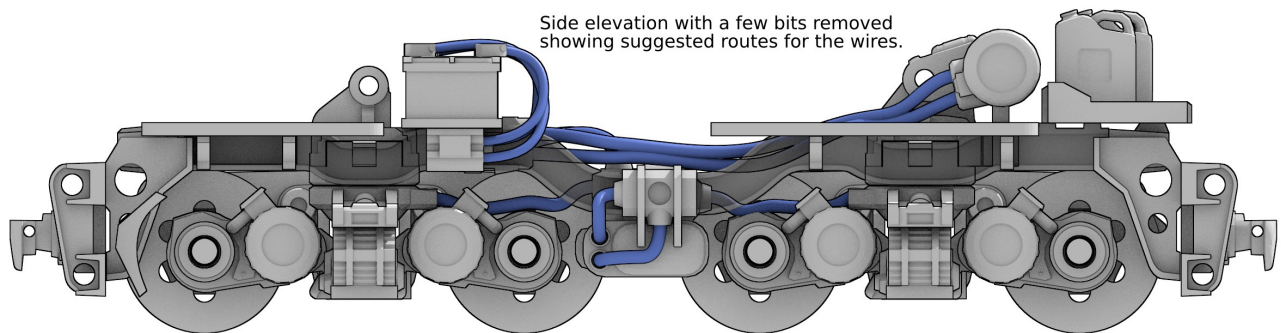
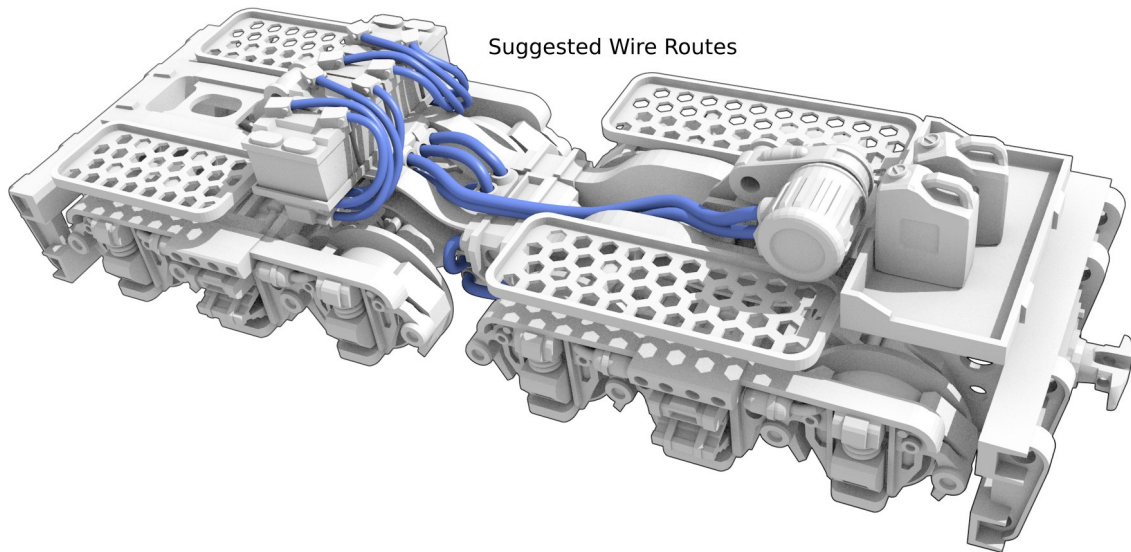

With the wires in place, the bogies clipped in, the assembly is ready for the bike. I used a couple of stubs of old nail to clip the bike in place. The fit was tight enough that I did not bother gluing it. This means the bike's suspension works too.

Here are some detailed photos of the bike's connection to the 3d printed assembly.



And that's it. Other details such as canvas roles, sachels and the like I will add, but these will be made from oven baked modelling clay or rolled up tissue and PVA.

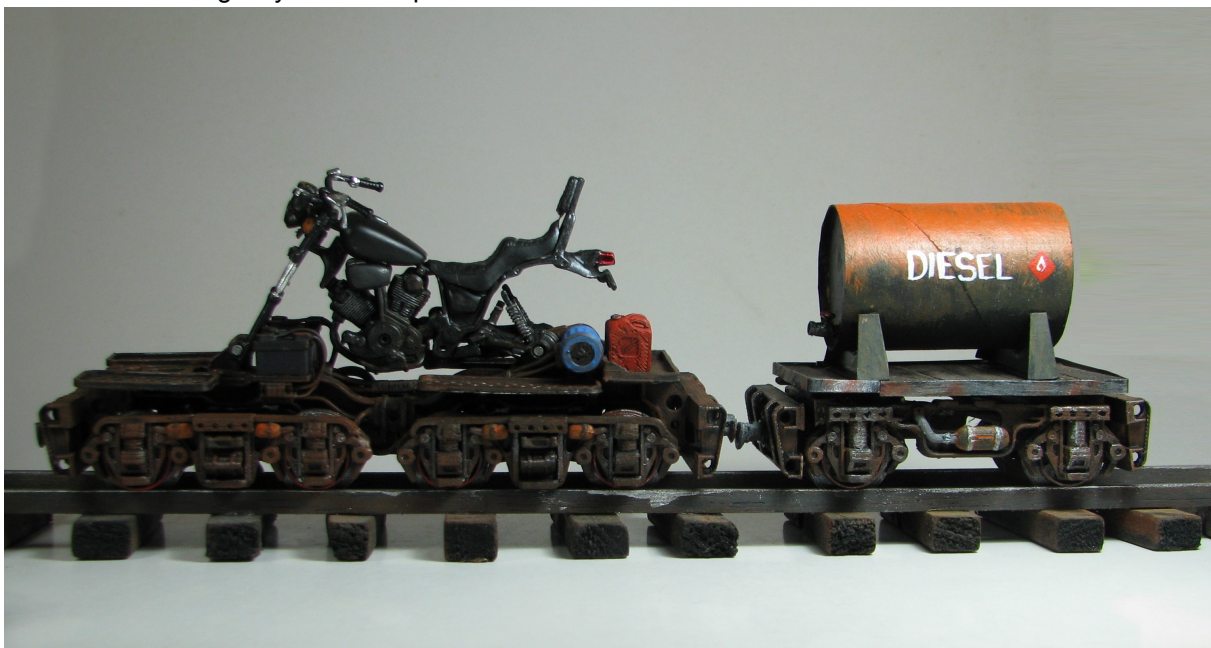

The 3D printed railbike model and design by Hamish Trolove are licensed under a [Creative Commons Attribution-NonCommercial-ShareAlike 4.0 International License](https://creativecommons.org/licenses/by-nc-sa/4.0/).

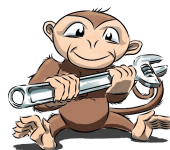

www.techmonkeybusiness.com