

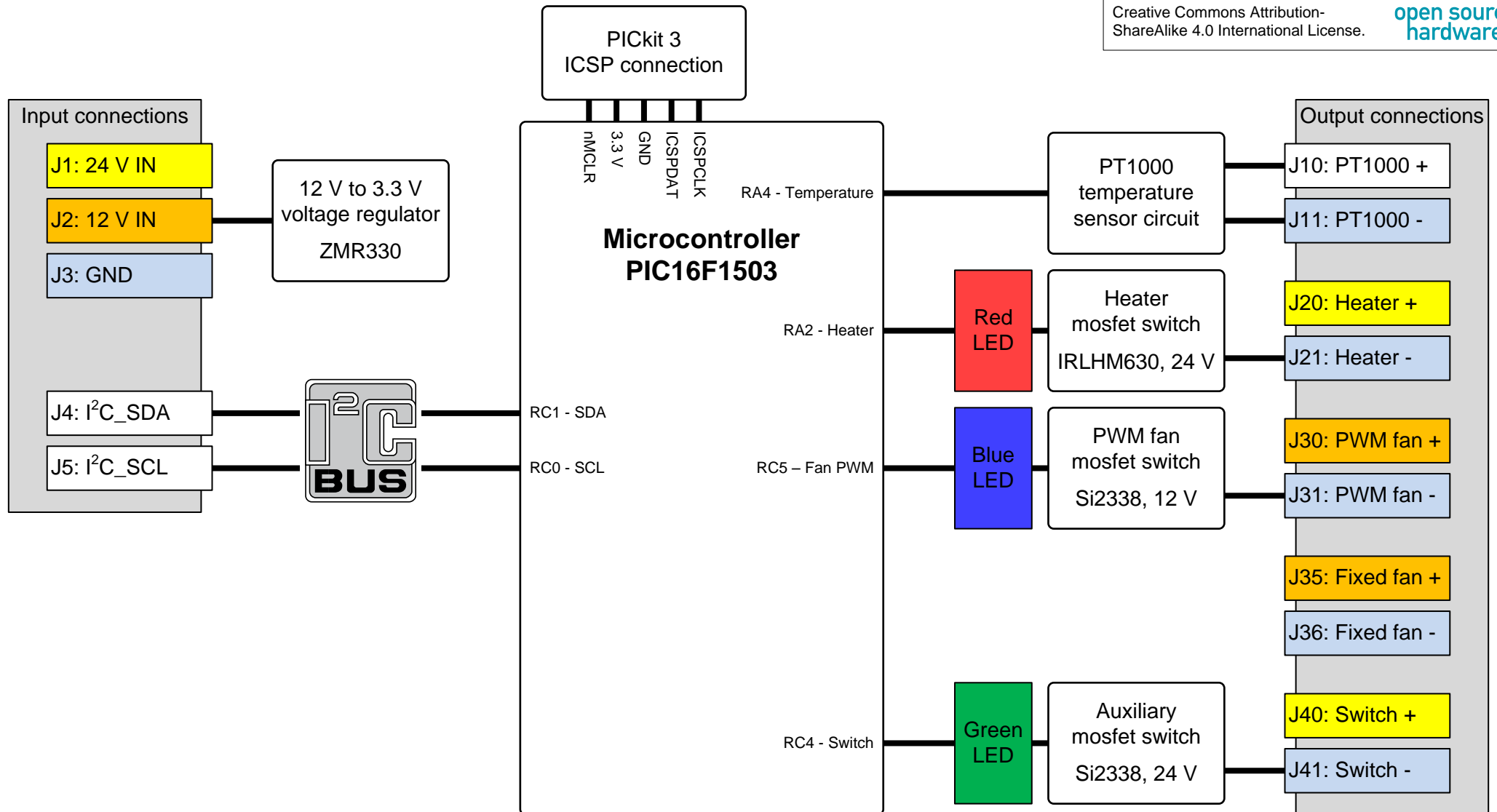

This work is licensed under a Creative Commons Attribution-ShareAlike 4.0 International License.

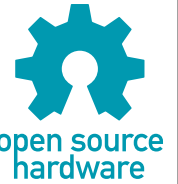

Title <b>Printhead controller</b>			Document type <b>Block diagram</b>		
Document number	Rev	Release state	Date		
	<b>-00</b>	<b>Prototype</b>	<b>2015-06-17</b>		
Drawn by	Checked by	Size	Scale	Sheet	
<b>J. Bischof</b>	-	<b>A4</b>	-	<b>1/1</b>	

**NEMESIS**  
3D printer project