

How to lubricate linear bearing using Greaser

- Greaser comes in two sizes - to fit 1515 and 2020 extrusion
- And two types of inlet types - Pump type if you will use a bike grease pump, Syringe type if you will use a syringe.

*The illustrations below is Greaser 1515 Pump type on a 1515 extrusion. Same procedure applies to 2020 exxtrusions.

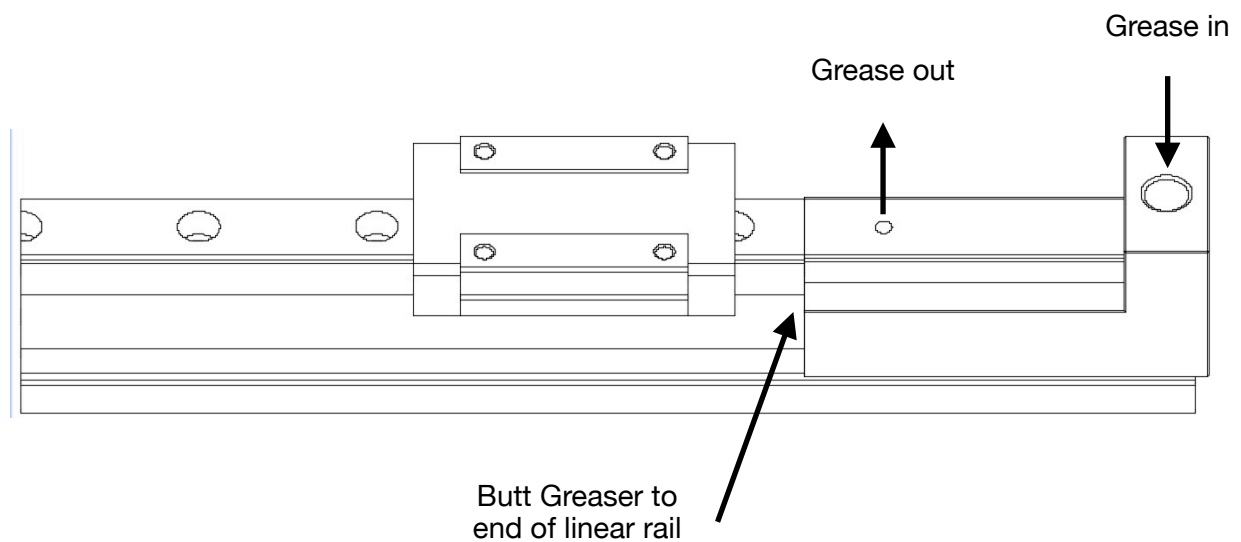
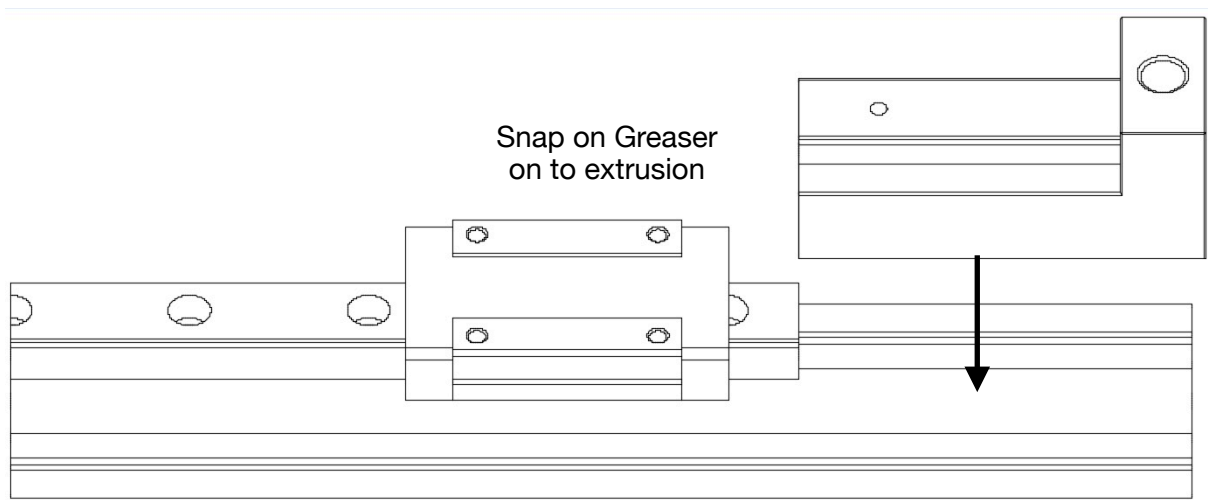

- To lubricate the bearing completely, position the bearing at three different points. At each position, inject grease until grease comes out the sides of the bearing.
- Slide the bearing two full lengths to distribute the grease.
- Repeat as needed.

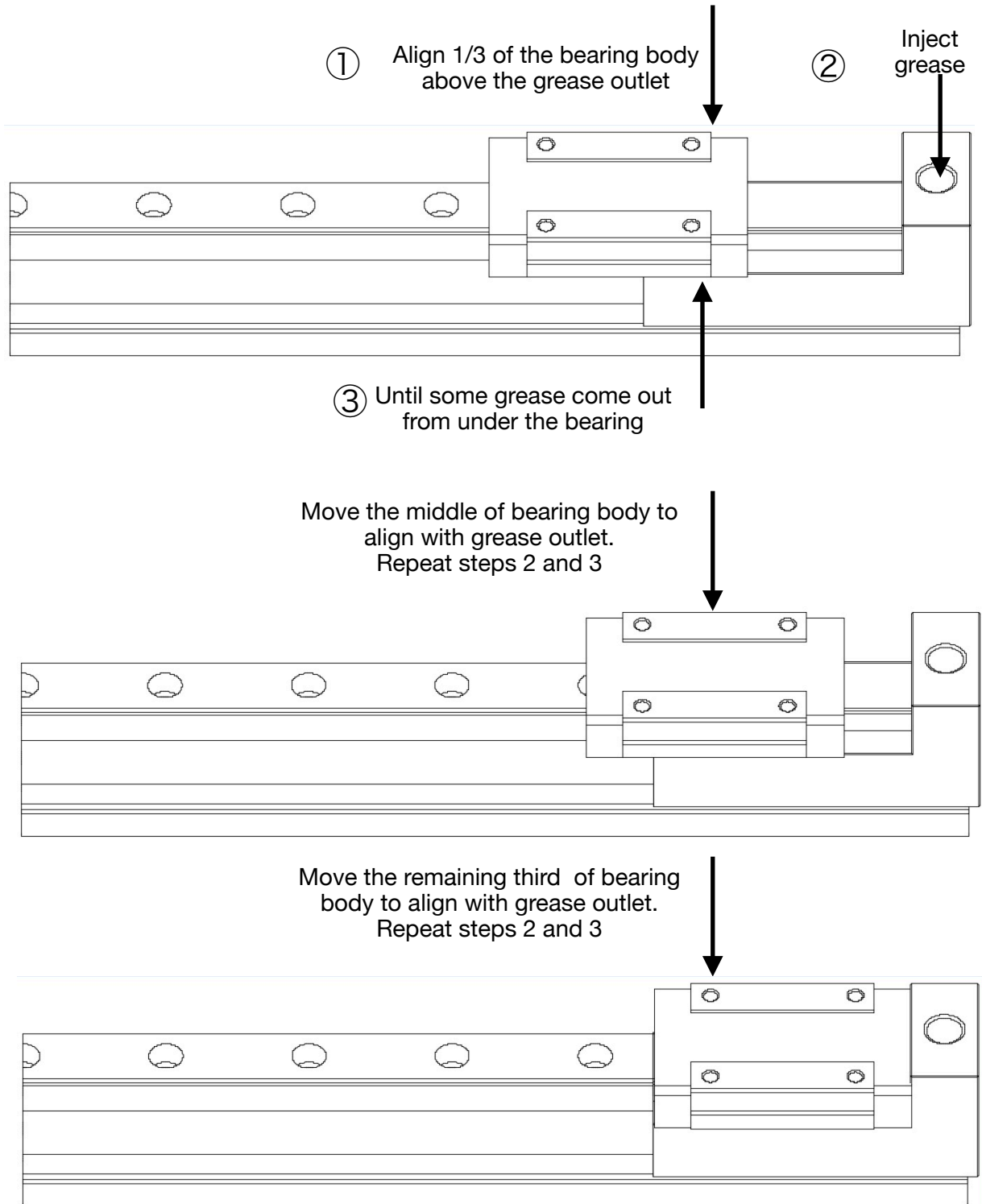

- Slide bearing back and forth to spread the grease evenly. Repeat above as necessary.

