

ULTIMAKER ACADEMY

Ikea Kvartal home improvement: Instructor Guide

**Toolkit for Continuing Professional Development
for Teachers**



Ikea home improvement, custom fit wall spacer

Instructor Guide

Getting Started.....	2
The tools and the process are the most important.....	2
Projectbrief.....	3
Design considerations.....	3
Project Overview.....	3
Learning Outcomes.....	3
Prerequisites	3
Project Discussion Guide.....	4
Essential Project Conceptual Questions.....	4
Essential Project Design Questions.....	4
Teacher Preparation.....	4
Day-to-Day Plans.....	4
Understand.....	4
Explore.....	5
Define.....	5
Ideate.....	5
Prototype.....	5
Refine.....	5
Solution.....	6
Differentiation.....	6
Non-Native Speakers.....	6
Special Needs Students.....	6
STEAM Connections.....	7
Science.....	7
Technology.....	7
Engineering.....	7
Art.....	7
Math.....	7
Produce It	7
Assessment Processes	7
Design Criteria Worksheet.....	8
Who	8
What.....	8
Where	8
Why.....	8
Pre-Test.....	9
Post-Test.....	11
Pre- and Post-Test Evaluation Rubric.....	13
Instructions.....	23

Ikea home improvement, custom fit wall spacer



picture 01

Getting Started

The tools and the process are the most important

The skills of the students in designing can be developed when they think about home improvement. Ikea products are very popular, but some products need adjustments. We created an adjustment for the Ikea Kvartal. The students have to think about design steps, the functional requirements and technology for manufacturing and 3D printing. Every student begins by answering some questions:

- What is the main function of the wall spacer?
- What are the design features that will support the basic function of the product?
- What is the ideal size, shape, and weight of the spacer?
- What materials are the best to make this product?
- Which geographic location, and what target audience is this Ikea home improvement designed for?

Project brief

If you want to start this project, your first task is to develop some skills in using Solidworks® software to create the spacer. After completing the basic product, the students are encouraged to create and design their own products and they have to apply their knowledge of the software Solidworks® in a new environment to generate multiple concepts. With this project, the students will increase their ability to work with the software, and they will use the power of the design thinking process. They will also learn how to work with 3D printers.

Design considerations used this project are as follows:

- Design goal: Is the wall spacer a practical design that could achieve its function?
- Design appearance: What does it look like? What is it made of? What are the measurements?
- Target: Who will be using the product? What is important to them?
- Mass production: Can the spacer design scale up to mass production?
- How long does it take?

Project Overview

This project is about the custom fit wall spacer (see *picture 01*). The wall spacer is designed in Solidworks and converted to gcode in Cura. With this product it is possible to place the Ikea Kvartal on the wall.

Software: Solidworks, Cura

Time: 1-3 hours

Difficulty: Beginner

Subject: Mechanical Engineering, Maths

You can find the video tutorial via this link:

<https://www.youtube.com/watch?v=NCLmCW9NxJ4>.

Learning Outcomes

After this project, students will be able to:

- Demonstrate skills in using Solidworks to create products for Mechanical Engineering.
- Create their own 3D products
- See how the product from Solidworks will look like in real life.
- Demonstrate skills related to incorporating virtual and physical representations of mechanical engineered products into a variety of presentation formats that can include written essays, and oral and visual presentations.

Prerequisites

If you are not familiar with the Solidworks software, we recommend that you view the online tutorials, to increase your knowledge:

<https://www.solidworks.com/sw/resources/solidworks-tutorials.htm>

Project Discussion Guide

Essential Project Conceptual Questions

- Why is the study of a costum wall spacer considered to be a valuable project for teaching Mechanical Engineering?
- What went 'wrong' with the original product? Why is it necessary to build a wall spacer?

Essential Project Design Questions

- What type of material is used to create the costum wall spacer?
- What are the design features the spacer should have to serve?
- What was wrong with the original product?
- What are the measurements of the wall spacer?

Teacher Preparation

- Be prepared to help the students with questions in Solidworks.
- Show and learn students how to work with new software techniques.
- Show students where they can use the software Help feature.
- Make a list of videos where the students can take a look at when they need reference for their project.

Day-to-Day Plans

We divide the designing process in 7 phases.

- Understand
- Explore
- Define
- Ideate
- Prototype
- Refine
- Solution

Understand: Watch the students

To establish a solid foundation for the costum wall spacer project, students need to have a clear understanding about the project and what is asked from them. The best point to start is to review the project design brief. The second action is to distribute the student pre-test and give students 10 to 20 minutes to answer the questions. Your next job is to facilitate a student discussion built around the pre-test questions.

Explore: Develop a knowledge base

In this phase you want students to develop an understanding of the function of this wall spacer. A good start is to form teams where students can discuss the project and the project design questions listed above.

Define: Clarify Requirements

This is a very important stage where the students have to establish the criteria for the project. You will need to understand specific parameters related to factors such as Solidworks, product dimensions, materials used and construction techniques.

Ideate: Creativity

In this phase the students must base their design on the criteria that they have made in the previous stage. They have completed their research and they can justify why specific choices are made. Students can justify their choices in a number of ways, sketches on paper, study models (out of simple materials) or by using Solidworks. Students will be able to communicate visually to others what they made and what they are going to refine in the next phase.

Prototype: Test

In this phase, students make a prototype of the product. They will print their spacers. Students learn the skill to make their designs reality. Your job is to encourage students to assist each other in learning the software

Refine: Almost There

Almost done with the project. The students will criticize their prototype, and refine them to a better product. When the students are proceeding this phase, it is your job to remind them to keep referring to the criteria they have established at the beginning.

Solution: Final Presentation

The last phase is also very important. In this stage you ask your students to give a presentation about how it helped them expand the four C's of their learning skills.

- Critical thinking
- Communication
- Collaboration
- Creativity

The presentation should be about the most important aspects of each of the previous phases. Students should be aware from the beginning of the project that the results in design phases 1-7 will culminate in a final presentation. Stress the importance of using tools to visualize and present in the same way professionals do. When time is limited, it is also possible to let students share their presentations electronically.

Differentiation

- Let students view some relevant videos in small groups.
- Show the students websites that can help them in the Define and Explore stages.
- Make small teams collaborate on the last four design phases. Some students will focus on the sketches and others will focus on digital prototyping.
- Let students evaluate others and themselves at the end of every phase.
- Give the students some models of successful student presentations, so they can see what is needed to complete the project.

Non-Native Speakers

- Provide English dictionaries or electronic translation devices.
- Allow the student to create presentations in their primary language and have it translated later.
- Pair ELL students (English Language Learners) with students that speak English very well.

Special Needs Students

- Show the student prefabricated models.
- Let assistants help the students in sketch modeling and prototypes.
- Make it possible for the students to work with larger font sizes, speech recognition and alternative input devices.

STEAM Connections

Science

The chemical part of this project is the material. What happens at the atomic level when the plastic is heated and melted to be used in a 3D printer?

Technology

What does the choice of material tell you about the technology? What technologies can you use to manufacture the wall spacer? What are the pros and cons of the production techniques?

Engineering

What properties do the materials that you use in this project that make them well-suited to being used as a spacer? In which other applications is this material used? How would you manufacture this product if you did not have a 3D printer?

Art

How can you make the wall spacer in such way that it fits in a designer room? Which shapes, materials and colors do you use? What other kind of art can you make with a 3D printer?

Math

For math class, a teacher prepare calculation e.g.:

- What is the volume of the custom wall spacer?
- How many spacers will fit in one cubic meter?
- What is the surface area of the object?

Produce It

Activities where you have to produce something can take some time, but the benefits are worth it. When you ask former students what they remember about their schoolperiod, the answer often refers to something they made, wrote, or performed.

Assessment Processes

For each project students complete a self evaluation and peer evaluation. These are accompanied by the evaluation that the teacher have made.

The STEAM questions, Extension Ideas, and the Build It activity offer students an opportunity to take what they learn in the process and apply the knowledge to increase the quality of their work and increase their scores.

Design Criteria Worksheet

In this challenge, students have to apply their technical skills to use Solidworks to create a 3D model of the spacer. It is very important that you develop an understanding of all relevant design criteria. This chapter helps you with the developing by prompting a response to questions in four categories: Who, What, Where and Why.

Who?

- Who will buy the wall spacer?
- Who will use it?
- Who will have to be in the same room with it?
- Who will design it?
- Who will mass-produce the product?
- Who is involved with the discovery, extraction, and transport of materials used in the wall spacer?

What?

- What design features are crucial to the functionality?
- What materials will it be made of?
- What ways of manufacturing do you use?
- What are the functions that it has to fulfill?

Where?

- Where will the wall spacer be used?
- Will the product be used by more than one people or object?
- Where can the materials required to create the spacer be found?

Why?

- Why are you designing a custom wall spacer?
- Why are the specific materials you choose well-suited to produce this product?

Pre-Test

Discussion

Why is the wall spacer created?

.....
.....

What are the design features a wall spacer should have to serve not only its primary functional purpose but other purposes as well?

.....
.....

Why should we print this product instead of melt in into a mold?

.....
.....

Survey

Fill the surface visualised in table *Custom fit wall spacer 1*

To what extent do you agree/ disagree with the following sentences:

1. Strongly disagree
2. Disagree
3. Neutral
4. Agree
5. Strongly agree

	1	2	3	4	5
I understand what a wall spacer does, why it was introduced, and how people use it.					
I understand the most important functional as well as other design features of the product.					
I understand the importance of appropriate material choice.					
I have used Solidworks before and understand the program.					
I understand the seven phases of design thinking.					

Table: *Custom fit wall spacer 1*

Post-Test

Discussion

Why is the wall spacer created?

.....
.....

Describe how your response to this question changed as a result of your experience with this project.

.....
.....

What are the design features a wall spacer should have to serve not only its primary functional purpose but other purposes as well?

.....
.....

Describe how your response to this question changed as a result of your experience with this project.

.....
.....

Why should we print this product instead of melt in into a mold?

.....
.....

Describe how your response to this question changed as a result of your experience with this project.

.....
.....

Survey

Fill the surface visualised in table Custom fit wall spacer 2

To what extent do you agree/ disagree with the following sentences:

1. Strongly disagree
2. Disagree
3. Neutral
4. Agree
5. Strongly agree

	1	2	3	4	5
I understand what a wall spacer does, why it was introduced, and how people use it.					
I understand the most important functional as well as other design features of the product.					
I understand the importance of appropriate material choice.					
I have used Solidworks before and understand the program.					
I understand the seven phases of design thinking.					

Table: *Custom fit wall spacer 2*

Pre- and Post-Test Evaluation Rubric

See the tables *Custom fit wall spacer 3* until 11

	Excellent <i>4 points</i>	Good <i>3 points</i>	Fair <i>2 points</i>	Poor <i>1 points</i>
Pre-Test	Great care was taken in reading and answering all questions. Maximal engagement in group sessions. A leadership role assumed.	Care was taken in reading and answering all questions. Demonstrated a willingness to engage in group discussions.	A minimal amount of care was taken in reading and answering all questions. Minimal engagement in group discussions.	No care was taken in reading and answering all questions. No engagement at all in group discussion.
Post-Test	Great care was taken in reading and answering all questions. Maximal engagement in group sessions. A leadership role assumed.	Care was taken in reading and answering all questions.. Demonstrated a willingness to engage in group discussions.	A minimal amount of care was taken in reading and answering all questions.. Minimal engagement in group discussions.	No care was taken in reading and answering all questions. No engagement at all in group discussions.

Table: *Custom fit wall spacer 3*

Prerequisite Skills Preparation Evaluation

	Excellent <i>4 points</i>	Good <i>3 points</i>	Fair <i>2 points</i>	Poor <i>1 points</i>
How-to Videos	The videos are used with great care to develop the skills that are necessary for the project.	The videos are used with care to develop the skills that are necessary for the project.	The videos are used with a minimal amount of care to develop the skills that are necessary for the project.	The videos are used with no care to develop the skills that are necessary for the project.
Collaboration and Participation	The student made exceptional effort to work with other students to improve competencies with the prerequisite skills	The student made reasonable effort to work with other students to improve competencies with the prerequisite skills	The student made minimal effort to work with other students to improve competencies with the prerequisite skills	The student made no effort to work with other students to improve competencies with the prerequisite skills

Table: *Custom fit wall spacer 4*

Understand Phase Evaluation Rubric

	Excellent <i>4 points</i>	Good <i>3 points</i>	Fair <i>2 points</i>	Poor <i>1 points</i>
Project Videos and Brief	The project videos and project brief are explored with great care	The project videos and project brief are explored with care	The project videos and project brief are explored with minimum amount of care	The project videos and project brief are explored with no care
Design Journal	In the Design Journal you can clearly see that the student attempted to improve the understanding of the project.	In the Design Journal you can see that the student attempted to improve the understanding of the project	In the Design Journal you can just see that the student attempted to improve the understanding of the project.	In the Design Journal you can not see that the student attempted to improve the understanding of the project.
Collaboration and Participation	The student made exceptional effort to clarify their understanding through discussion with others.	The student made effort to clarify their understanding through discussion with others.	The student made a minimum amount of effort to clarify their understanding through discussion with others.	The student made no effort to clarify their understanding through discussion with others.

Table: Custom fit wall spacer 5

Explore Phase Evaluation Rubric

	Excellent <i>4 points</i>	Good <i>3 points</i>	Fair <i>2 points</i>	Poor <i>1 points</i>
Deeper Inquiry	The student made exceptional effort to expand their understanding of the challenge, the factors that are part of the project, or the types and quality of solutions.	The student made effort to expand their understanding of the challenge, the factors that are part of the project, or the types and quality of solutions.	The student made a minimal amount of effort to expand their understanding of the challenge, the factors that are part of the project, or the types and quality of solutions.	The student made no effort to expand their understanding of the challenge, the factors that are part of the project, or the types and quality of solutions..
Design Journal	In the Design Journal you can clearly see that the student made excellent evidence of designing exploration. All the notes and sketches show an exceptional grasp of the project and the aspects that will have an impact on their own work	In the Design Journal you can clearly see that the student made evidence of designing exploration. All the notes and sketches show a grasp of the project and the aspects that will have an impact on their own work	In the Design Journal you can clearly see that the student made a minimum amount of evidence of designing exploration. All the notes and sketches show a minimum amount of grasp of the project and the aspects that will have an impact on their own work	In the Design Journal you can clearly see that the student made no evidence of designing exploration. All the notes and sketches show no grasp of the project and the aspects that will have an impact on their own work
Collaboration	The collaboration is excellent. The students listens very well and supports the other students.	The collaboration is good. The students listens well and supports the other students. He does not create conflicts.	The collaboration is fair. The students listens sometimes and supports the other students, but sometimes isn't a good team member	This student never listens and never helps other people. The student is not a good member for the team.

Table: Custom fit wall spacer 6

Define Phase Evaluation Rubric

	Excellent <i>4 points</i>	Good <i>3 points</i>	Fair <i>2 points</i>	Poor <i>1 points</i>
Design Criteria Worksheet	The student made exceptional effort to use the worksheet to expand their understanding of the challenge, the factors that are part of the project, or the types and quality of solutions.	The student made effort to use the worksheet to expand their understanding of the challenge, the factors that are part of the project, or the types and quality of solutions.	The student made a minimum amount of effort to use the worksheet to expand their understanding of the challenge, the factors that are part of the project, or the types and quality of solutions.	The student made no effort to use the worksheet to expand their understanding of the challenge, the factors that are part of the project, or the types and quality of solutions.
Design Journal	From the design journal becomes very clear that the student has identified the critical criteria for their project	From the design journal becomes clear that the student has identified the critical criteria for their project	From the design journal becomes just clear that the student has identified the critical criteria for their project	From the design journal becomes not clear that the student has identified the critical criteria for their project
Collaboration	The collaboration is excellent. The students listens very well and supports the other students.	The collaboration is good. The students listens well and supports the other students. He does not create conflicts.	The collaboration is fair. The students listens sometimes and supports the other students, but sometimes isn't a good team member	This student never listens and never helps other people. The student is not a good member for the team.

Table: *Custom fit wall spacer 7*

Ideate Phase Evaluation Rubric

	Excellent <i>4 points</i>	Good <i>3 points</i>	Fair <i>2 points</i>	Poor <i>1 points</i>
Ideation	The student made excellent effort to create concepts and solutions.	The student made effort to create concepts and solutions.	The student made a minimum amount effort to create concepts and solutions.	The student made no effort to create concepts and solutions.
Design Journal	From the design journal becomes very clear that the student has explored multiple design solutions.	From the design journal becomes clear that the student has explored multiple design solutions	From the design journal becomes just clear that the student has explored multiple design solutions	From the design journal becomes not clear that the student has explored multiple design solutions
Collaboration	The collaboration is excellent. The students listens very well and supports the other students.	The collaboration is good. The students listens well and supports the other students. He does not create conflicts.	The collaboration is fair. The students listens sometimes and supports the other students, but sometimes isn't a good team member	This student never listens and never helps other people. The student is not a good member for the team.

Table: *Custom fit wall spacer 8*

Prototype Phase Evaluation Rubric

	Excellent <i>4 points</i>	Good <i>3 points</i>	Fair <i>2 points</i>	Poor <i>1 points</i>
Prototype Development and Testing	The student made excellent effort to visualize and test prototypes.	The student made effort to visualize and test prototypes.	The student made a minimum of effort to visualize and test prototypes.	The student made not effort to visualize and test prototypes.
Design Journal	From the design journal becomes very clear that the student has documented and evaluated prototype(s).	From the design journal becomes clear that the student has documented and evaluated prototype(s).	From the design journal becomes just clear that the student has documented and evaluated prototype(s).	From the design journal becomes not clear that the student has documented and evaluated prototype(s).
Collaboration	The collaboration is excellent. The students listens very well and supports the other students.	The collaboration is good. The students listens well and supports the other students. He does not create conflicts.	The collaboration is fair. The students listens sometimes and supports the other students, but sometimes isn't a good team member	This student never listens and never helps other people. The student is not a good member for the team.

Table: Custom fit wall spacer 9

Refine Phase Evaluation Rubric

	Excellent <i>4 points</i>	Good <i>3 points</i>	Fair <i>2 points</i>	Poor <i>1 points</i>
Refine Solutions	The student made excellent effort to refine ideas. The solutions are very closely aligned to the design criteria.	The student made effort to refine ideas. The solutions are aligned to the design criteria	The student made a minimum amount of effort to refine ideas. The solutions are somewhat aligned to the design criteria	The student made no effort to refine ideas. The solutions are not aligned to the design criteria
Design Journal	From the design journal becomes very clear that the student has significantly enhanced the design through the use of the software	From the design journal becomes clear that the student has significantly enhanced the design through the use of the software.	From the design journal becomes just clear that the student has significantly enhanced the design through the use of the software.	From the design journal becomes not clear that the student has significantly enhanced the design through the use of the software
Collaboration	The collaboration is excellent. The students listens very well and supports the other students.	The collaboration is good. The students listens well and supports the other students. He does not create conflicts.	The collaboration is fair. The students listens sometimes and supports the other students, but sometimes isn't a good team member	This student never listens and never helps other people. The student is not a good member for the team.

Table: Custom fit wall spacer 10

Solution Phase Evaluation Rubric

	Excellent <i>4 points</i>	Good <i>3 points</i>	Fair <i>2 points</i>	Poor <i>1 points</i>
Preparation of Presentation	The student made excellent effort to make a perfect presentation.	The student made effort to make a good presentation.	The student made a minimum amount of effort to make a presentation.	The student made no effort to make a presentation.
Communication and Team Dynamics	Maximal effort was made to help the team conduct the final presentation.	Effort was made to help the team conduct the final presentation.	A minimum amount of effort was made to help the team conduct the final presentation..	No effort was made to help the team conduct the final presentation.
Presentation Content	The student made exceptional effort to create and present a solution that is aligned to the criteria for the project.	The student made effort to create and present a solution that is aligned to the criteria for the project.	The student made a minimum amount of effort to create and present a solution that is aligned to the criteria for the project.	The student made no effort to create and present a solution that is aligned to the criteria for the project.

Table: Custom fit wall spacer 11

Instructions





According to Ikea
this is what it should look like



But in real life things are allways
a bit more complicated..

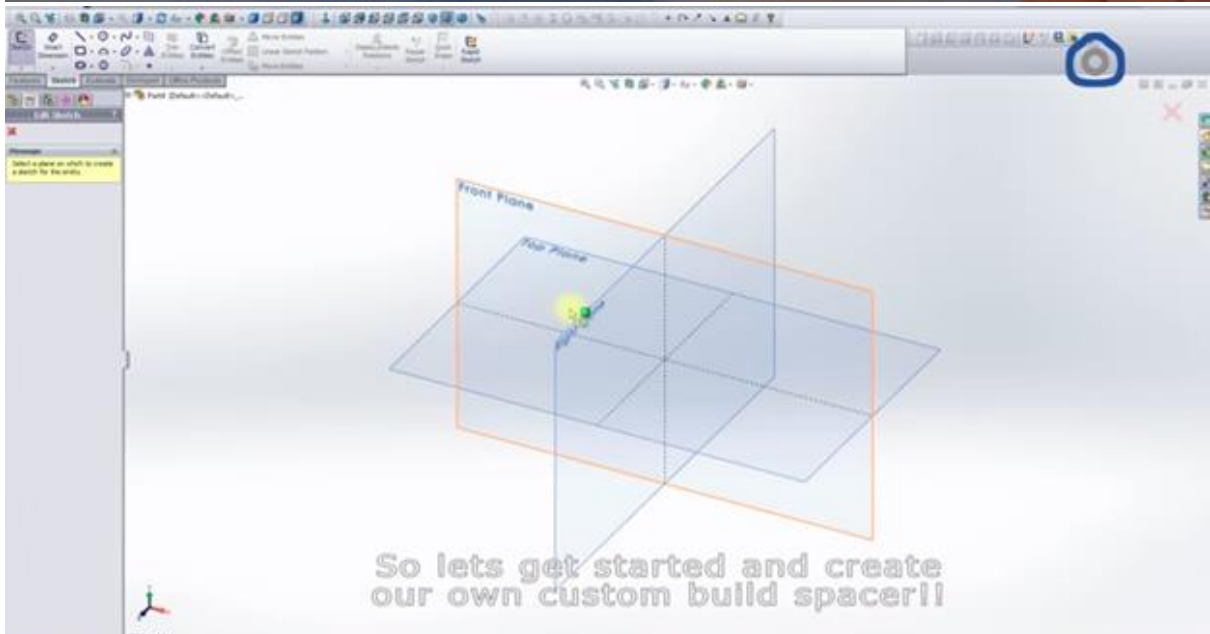

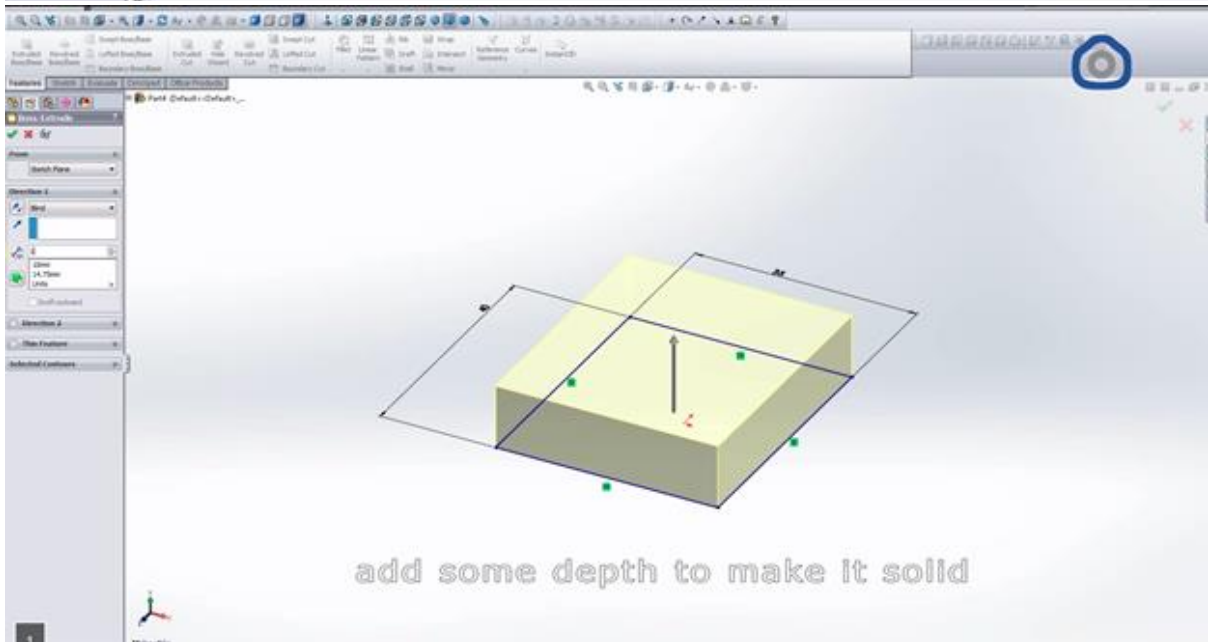
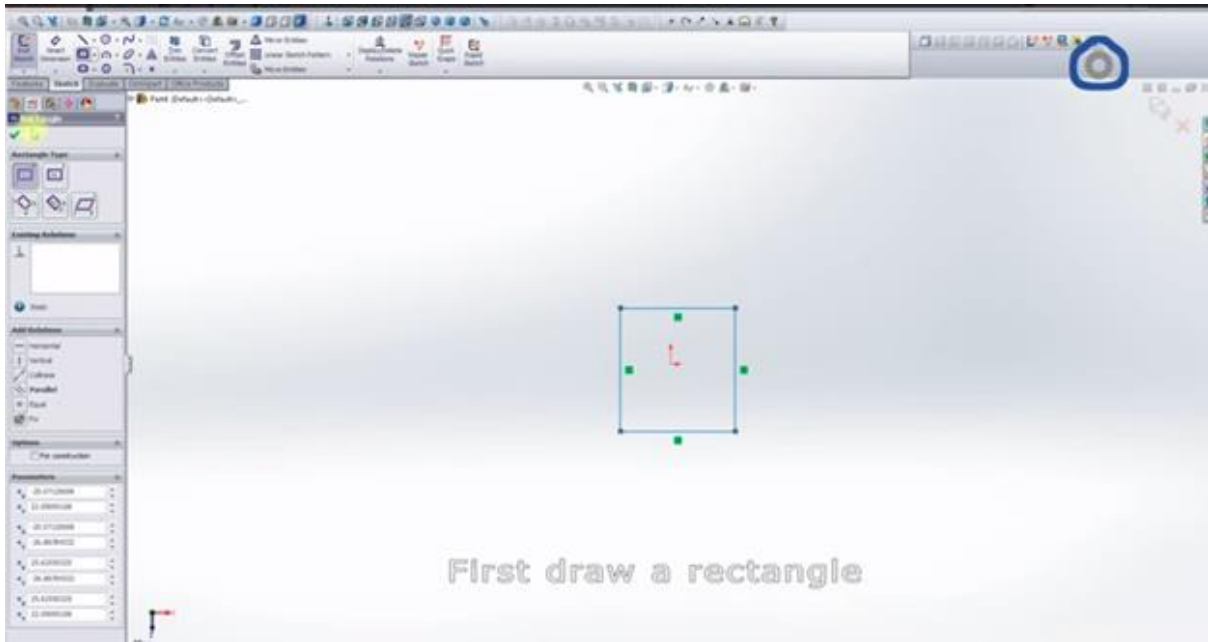

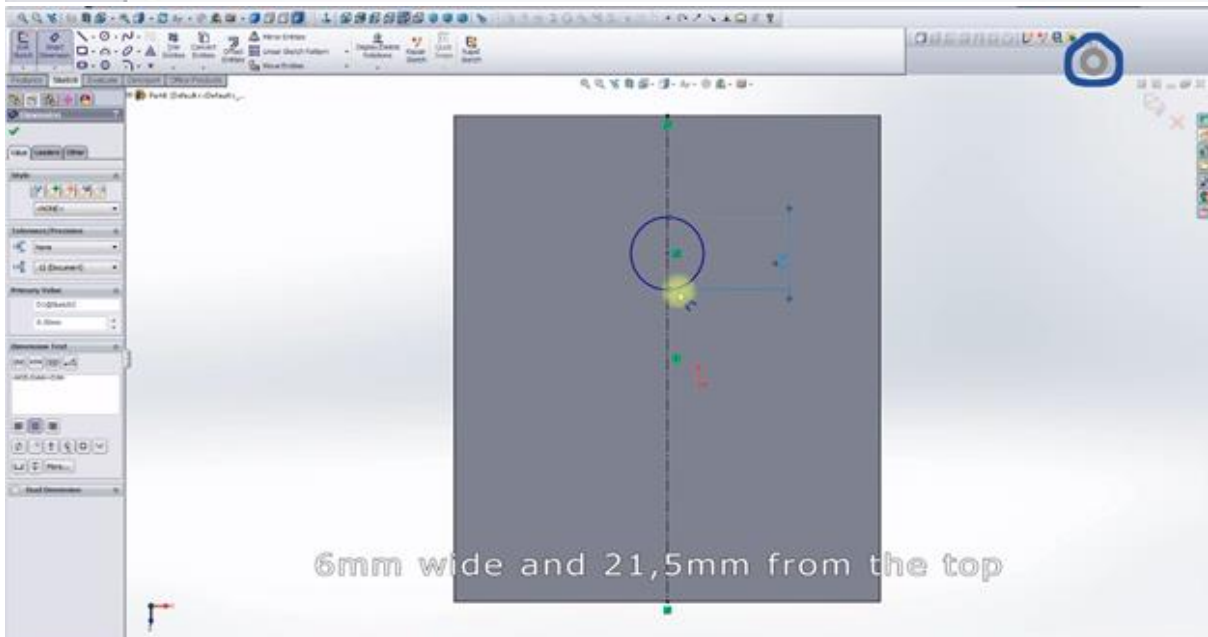
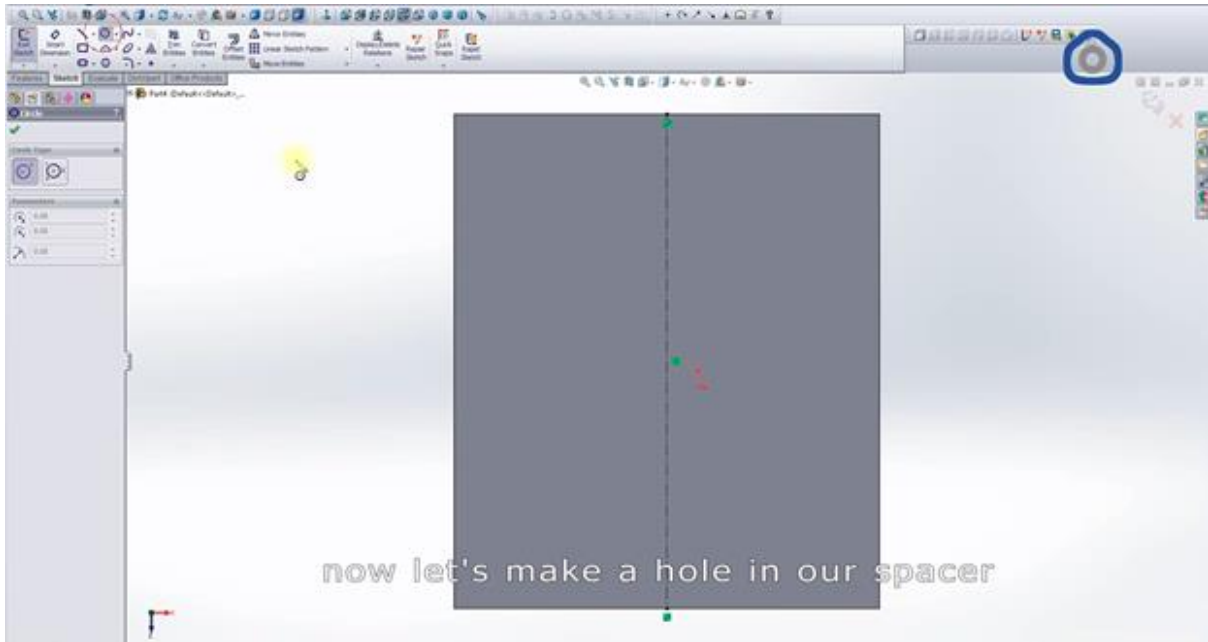

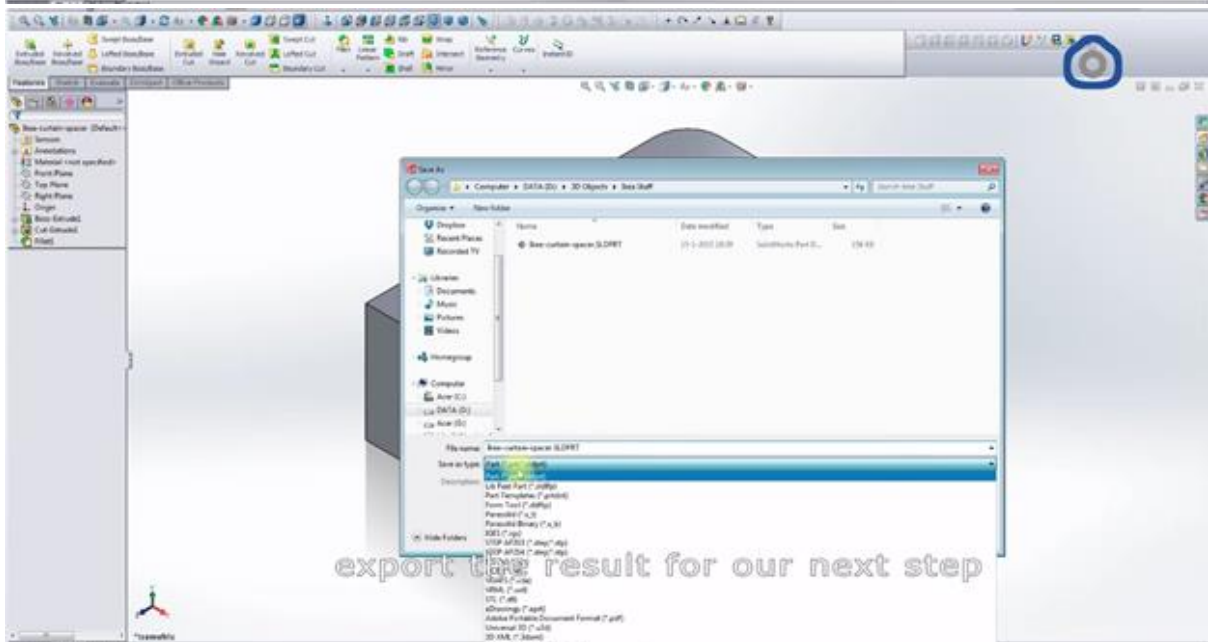
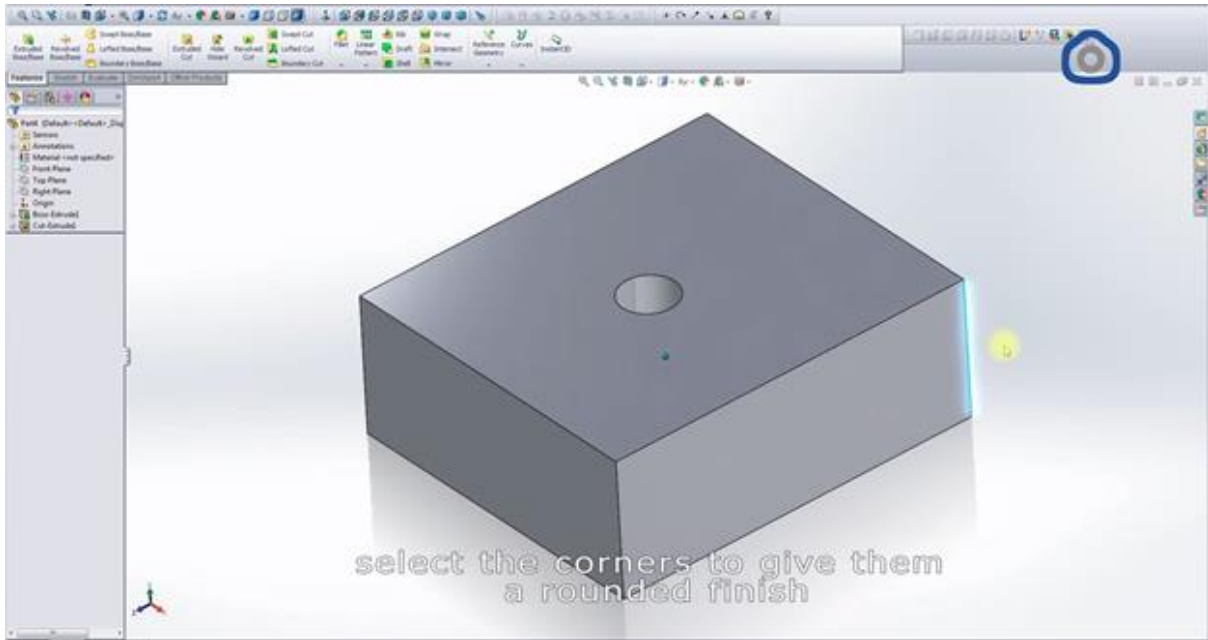

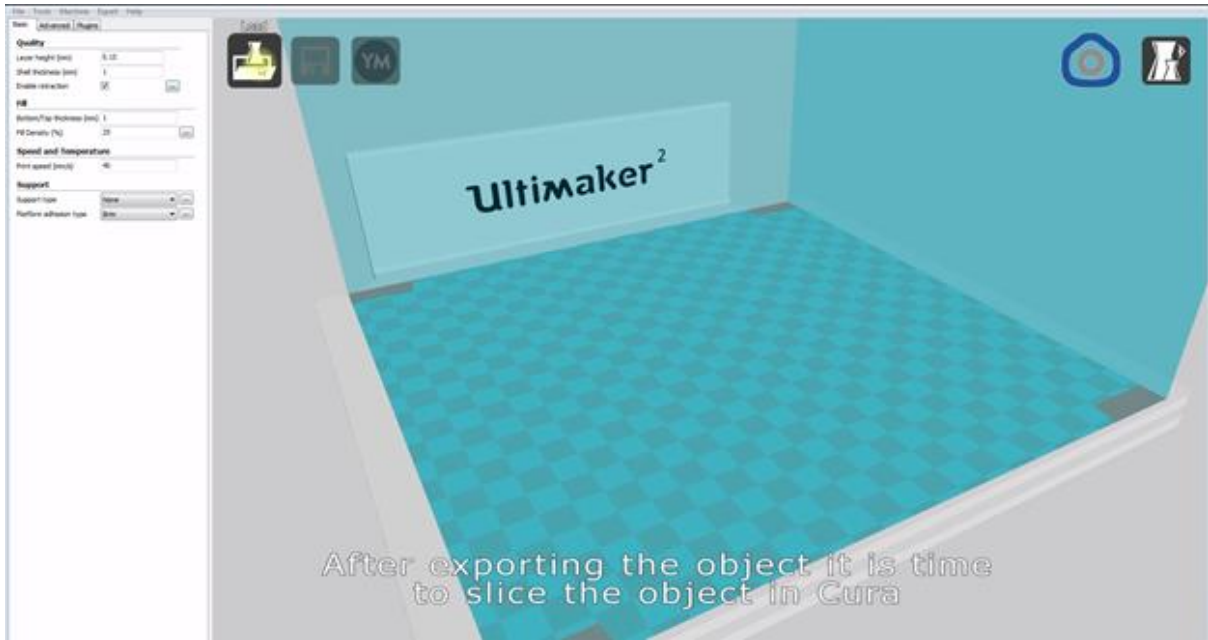

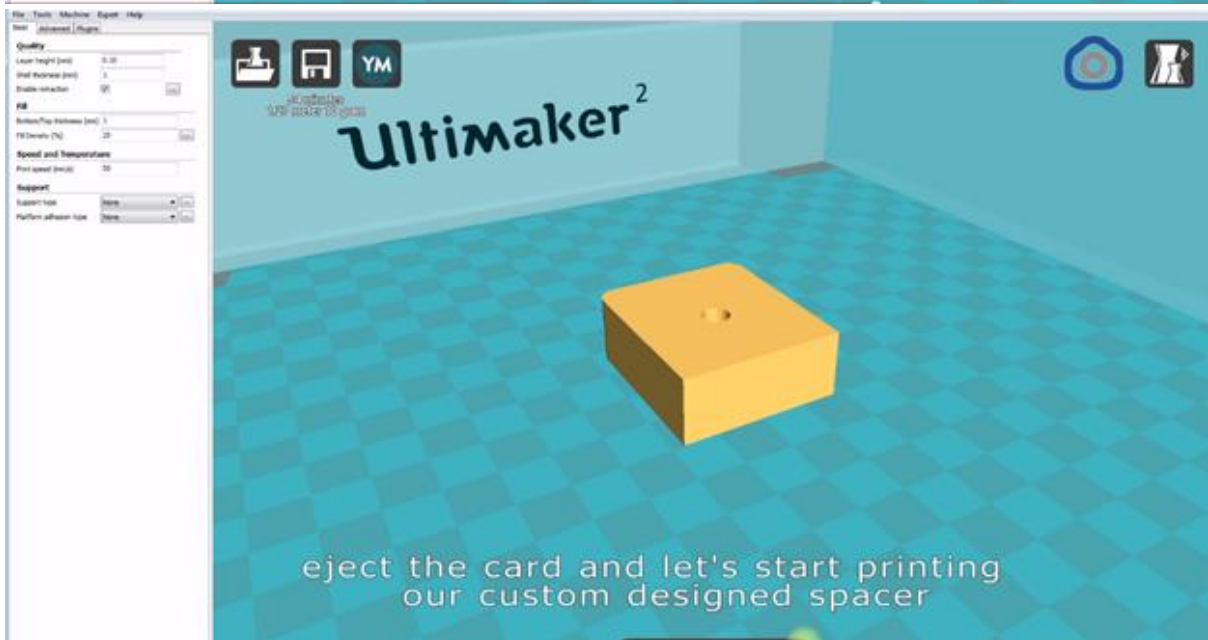

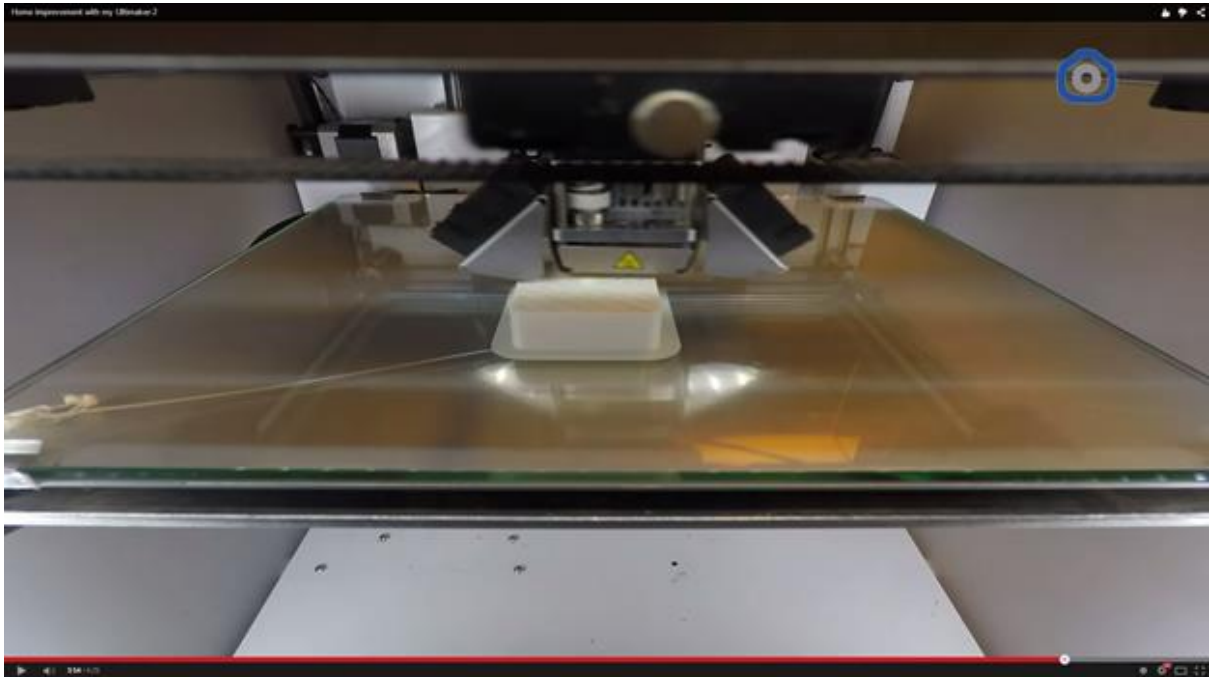
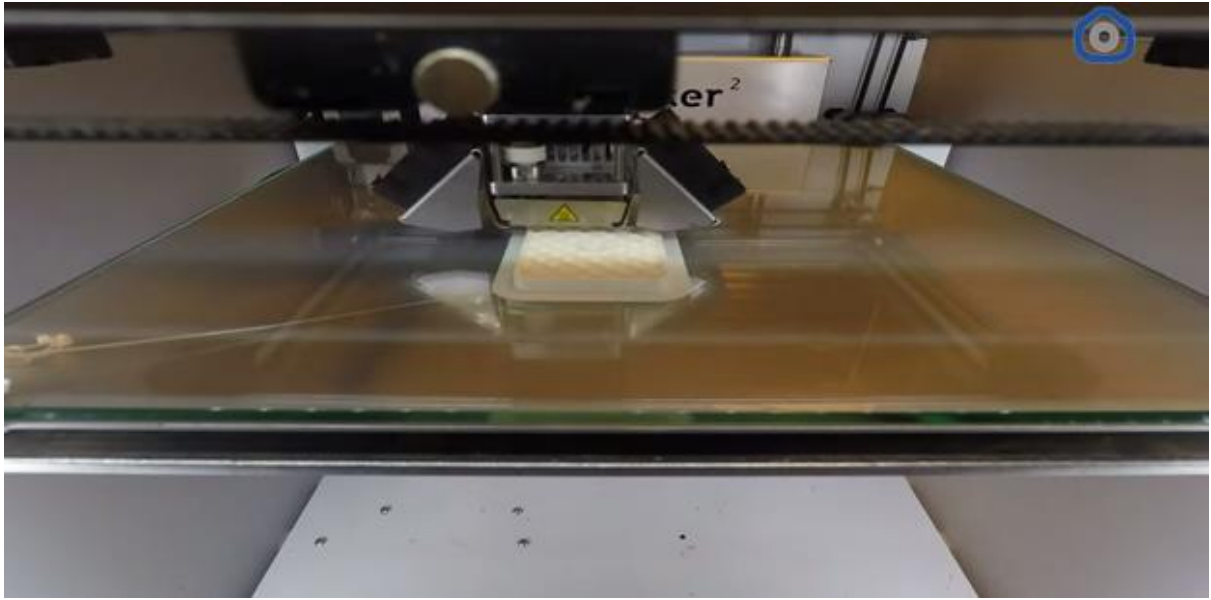





secure it with a philips screw



And for the rest:
follow the instructions provided by Ikea



Home improvement with my Ultimaker-2

End of Ikea Home Improvement Instructor Guide